

Commented [RM2R1]:

Commented [RM3R1]:

Just The Ticket



Catalogue - May 2022

Specialists in Tools, Materials, Parts & Kits for Garden Railways

15 Hillside Drive,
East Gomeldon,
Salisbury,
Wilts,
SP4 6LF.



www.justtheticketsupplies.co.uk ; www.facebook.com/Just-The-Ticket-Gauge-1

Tel: 01980 610058

e-mail: justtheticketeng@gmail.com

Just The Ticket Engineering Supplies

Just The Ticket Engineering Supplies is run by Roger Melton, a lifelong steam enthusiast and an active model engineer, railway enthusiast, railway operator, model traction engine owner and vintage railway carriage restorer of long standing, who will always do his very best to give you good service and competitive pricing.

Just The Ticket is not VAT registered so does not add VAT to its prices or to postage and packing, and will always endeavour to minimise postal charges. I do not have a minimum order value. Callers are welcome by appointment

Payment

I can now accept debit and credit cards, including American Express, but direct bank transfer is cheapest for all concerned. – my account details are listed on the invoice included with the goods. I can also accept payment by Paypal (send payment to JustTheTicketEng@gmail.com) but Paypal is expensive for me so I ask that you add 3% to your bill if paying by this method. If you pay by card, rest assured that I don't charge the card till the goods are dispatched!

All goods remain the property of Just The Ticket until payment has been received and cleared.

If there is a problem with your order, please give me a call and I will endeavour to sort it out as quickly as possible.

Prices

Prices shown are correct at the time of printing but can vary on an almost daily basis as new stock is delivered, therefore I reserve the right to amend the invoiced price to reflect any such increases. Oil and metal prices in particular, seem to go up on an almost daily basis. If prices vary significantly I will endeavour to contact you before dispatching the goods. The difference in price between older and newer stock explains apparent anomalies in the prices of outwardly similar items.

I'm not VAT-registered, so VAT is not payable on any of the items listed in this catalogue or on the associated postage – please bear that in mind if comparing prices with those of alternative suppliers!

Delivery

I always try to deliver as quickly as possible, but sometimes delays are inevitable, particularly when new stock has to be sourced so please bear with me if your order takes a little while to compile.

I still stock a wide range of Phoenix-Precision Paints but haven't listed them in the catalogue. The cost of sending them by courier (Royal Mail will not accept them) is offputting to most people but I'll still have them available at exhibitions but it would be sensible to order in advance to ensure that I have what you want on the day. If you want them by post, please call to discuss. Obviously, it makes sense to buy a few tins at a time to offset the cost of carriage, if going down that route.

Contact Details:

E-mail: JustTheTicketEng@gmail.com ; **Web site** www.justtheticketsupplies.co.uk ; **Phone:** 01980 610058

If trying to phone me, please bear in mind that the dog usually takes me for some exercise between 13.00 and 14.00! On the other hand, I'm not averse to receiving calls in the evening, or at weekends, if they're before 9pm. My answerphone is always on, even if the outgoing message isn't always up to date

Lastly, I'm always interested in adding new products to my catalogue, so please do get in touch if you think you have items that would be of interest.

Cover photo : A class 47 diesel built by Ian Farrance from a JTT kit, and fitted with Fosmotor bogies.

CONTENTS

Page

- 3. Section A – Marking, Measuring & Hand Tools
- 4. Section B – Materials
- 8. Section C – Cutting Tools
- 10. Section D – Fixings and Fasteners
- 15. Section E - Steam Fittings
- 16. Section F – Miscellaneous
- 17. Section G – Paint and Painting Sundries
- 17 Section H– Kits and Bits
- 18. The Project
- 19. ARMIG
- 20. Dee
- 21. 56XX
- 22. Q1
- 23. ARMIG Derivatives
- 24. 10mm scale 12V Electric steam outline locomotives
- 25. 10mm scale 12V Electric Diesel Locomotives
- 27. Whitemetal & lost wax brass locomotive castings
- 32. Carriage Kits
- 33. Carriage Components
- 34. GWR Lost wax carriage components
- 35. Cast Resin Wagon Kits
- 38. Lost Wax castings for Carriages & Wagons
- 40. Section J - Gas & ENOTS
- 41. Section K- Solders & Fluxes
- 42. Section L - Waterslide Transfers

SECTION A – MARKING, MEASURING AND HAND TOOLS

Steel rules	-	6"/150mm	£ 2.50
		12"/300mm	£ 3.50
Scribers – double ended (90deg)			£ 2.00
90 degree Engineers Squares		2"	£ 5.50
		3"	£ 5.90
		4"	£ 5.90
		6"	£ 6.00
		9"	£ 9.00
Engineering protractor		6"	£ 5.50
Dividers, inside/outside callipers		3"	£ 1.90
		4"	£ 2.20
		6"	£ 2.40
Toolmakers clamps		2"	£ 5.40
		2-½"	£ 5.90
		3"	£ 6.30
		4"	£ 8.50
Foliac jointing paste		50ml bottle	£ 3.00
Spanners			
BA Spanners -			
12 ba stainless steel combination spanner			£ 6.00
14ba stainless steel combination spanner			£ 6.00
16ba stainless steel combination spanner			£ 6.00
Budget open ended (forged, not pressed/stamped)			£18.00
Box spanners set, 0-10ba			£24.00
Miniature adjustable spanner			£ 5.90
Miniature metric open ended 7pc spanner set, 3-5.5mm			£10.50
Small metric combination 10pc spanner set, 4-11mm			£10.50
Nut runners, various sizes,			£6.90 ea
Hex Key sets			
Metric mini set, 7 pieces 0.7-3mm in plastic wallet			£ 6.60
Metric- 7 piece 1.5-6.90 mm in folding holder			£11.20
Imperial – 7 piece 5/64" – 3/8" in plastic clip			£ 9.10
Mini locking pliers (make very useful temporary clamps-			£ 5.50
Pack containing 1 ea 100mm round nose & 1 x 125mm long nose)			
Four piece pin chuck set			£ 7.80
Fibreglass cutting disk for Dremel-type tools, Pk 5			£ 2.50
Fibreglass burnishing pen			£ 4.70
(Ideal for cleaning up soldered joints in etched kits)			
Refill for fibreglass pen			£ 1.20ea
0.2mm oiler pen			£ 4.40ea
Layout blue (100ml approx.)			£ 5.50ea (cannot be sent by post)
Brass blackening kit (can be diluted 1/10 for use) (100ml)			£ 9.50ea
Hinged inspection mirror			£7.70ea

SECTION B - MATERIALS

Priced per foot, except for gauge plate (18" lengths) and silver steel (13" lengths). **sold by the inch, pro-rata *lead, free cutting. Larger sizes are available but not necessarily list - please inquire.

<u>Round Bar</u>		<u>Bronze PB102</u>					
<u>Diameter</u>	<u>BMS†</u>	<u>Brass</u>	<u>PGMS</u>	<u>Sil. Steel</u>	<u>St. Steel</u>	*SAE660 **Colphos 90	Copper C106
1/32"					£1.70		
1/16"/2mm	£0.80	£0.70		£0.80	£2.60		
3/32"/2.5mm	£1.00	£1.50		£0.80	£4.00		
1/8"/3mm	£1.00	£1.50		£2.50	£2.50	£2.80	£3.80
5/32"/4mm	£1.00	£1.70		£3.00	£2.90		
3/16"/5mm	£1.00	£2.00		£3.50	£3.80	£3.00	£4.50
7/32"	£1.50	£2.30			£4.10		
1/4"	£1.60	£2.50	£2.50	£4.50	£4.90	£7.00	£6.80,
5/16"	£1.60	£2.80	£2.50	£3.80	£5.40	£10.50**	
3/8"/10	£1.70	£3.80	£3.20	£5.10		£12.00**	
		£2.20		3/8" half round			
7/16"	£1.50	£5.50	£3.95				
1/2"	£2.00	£6.50	£4.50		£6.60	£21.60*	
9/16"	£2.30	£7.20	£5.80				
5/8"	£2.50	£8.90	£6.45			£33.80	
3/4"	£3.60	£12.60	£8.00	£9.20		£48.7	
7/8"	£2.40	£13.20		£11.85**	£9.60		
1"	£4.00	£18.00**		£14.60**			
1-1/4"		£34.00**					
1-1/2"	£6.50**	£38.40**					
1-3/4"		£48.00**					
2"		£60.00**					
2-1/4"		£80.00**					

SAE 660 is a free-machining, continuously cast bronze that does not , so well suited to making boiler fittings as it will not go brittle from zinc loss

<u>Sheet metal (per sq ft)</u>					
<u>Thickness</u>	<u>BMS</u>	<u>Copper</u>	<u>Nickel Silver</u>	<u>Tinplate</u>	<u>Brass</u>
10g (3.25mm)		60.00			£46.00
16g (1.5mm)	£18.00	£32.00	55.00		£34.00
18g (1.20mm)	£15.00	£24.00			£28.10
20g (0.90mm)	£10.50	£22.00	£32.90		£20.10
22g (0.70mm)		£17.50			£19.00
24g (0.50mm)		£14.00	£27.90		£19.90
26g (0.40mm)			£31.90	£5.40	£14.50
28g (0.35mm)			£27.90		£12.30

<u>Angle Size</u>	Per ft * Metric equivalent		**black steel		
	<u>Bright Steel</u>	<u>Brass</u>		<u>Bright Steel</u>	<u>Brass</u>
1/4" x 1/4" x 1/16"		£2.80	1/2" x 1/2" x 1/8"	£4.50	£4.50
5/16" x 5/16" x 1/16"		£6.30	3/4" x 3/4" x 1/16"		£5.50
3/8" x 3/8" x 1/16"		£3.80	3/4" x 3/4" x 1/8"	£1.50**	£6.50
1/2" x 1/2" x 1/16"		£4.40	1" x 1" x 1/8"	£2.10*	£9.00
5/8" x 5/8" x 1/16"		£5.00	1-1/8" x 1-1/8" x 1/8"		£11.00*
3/4" x 3/4" x 1/16"		£5.50	1/8"		
3/4" x 3/4" x 1/8"		£8.00			

Rectangular Bar	BMS	Brass	Gauge plate	Copper or (S/S)	Rectangular bar	BMS	Brass	Gauge plate	Copper
1/16" x 1/4"	£1.00	£3.50							
1/16" x 3/8"	£1.20	£2.00			5/16" sq	£0.90	£3.80		£5.00
1/16" x 1/2"	£1.50	£2.50	£5.30		5/16" x 1/2"	£1.00	£4.50		
1/16" x 3/4"	£1.50	£3.00	£5.55		5/16" x 1"	£1.90	£9.00	£10.50	
1/16" x 1"		£3.40	£5.40		5/16" x 1-1/2"	£2.40		£13.60	
1/16" x 1-1/2"		£4.50							
					3/8" sq	£0.90	£4.70		
					3/8" x 1/2"	£1.20	£6.00		
					3/8" x 3/4"	£1.80	£8.50		
25mm x 2mm	£1.50								
1/8" sq	£1.00	£1.80			3/8" x 1"	£2.00	£10.20	£13.10	
1/8" x 3/16"					3/8" x 1-1/4"	£2.50		£15.20	
1/8 x 1/4"	£1.20	£2.20			3/8" x 1-1/2"	£2.80		£17.10	
1/8" x 3/8"	£1.50	£3.30			7/16" sq	£1.80	£6.00		
1/8" x 1/2"	£1.60	£2.70	£6.40	£2.50(s/s)	1/2" sq	£2.00	£8.50		
					1/2" x 3/4"	£4.00	£11.90		
1/8" x 5/8"	£1.90	£2.90	£6.70		1/2" x 1"	£4.60	£14.90	£15.80	
1/8" x 3/4"	£1.90	£3.40	£7.40		5/8" sq	£4.50	£10.00		
					5/8" x 3/4"	£5.40			
1/8" x 1"	£2.20	£4.90	£7.90		3/4" sq	£6.00	£13.30**		
1/8" x 1-1/4"	£2.25	£5.40	£8.20		1" sq	£8.50	£22.50**		
1/8" x 1-1/2"	£2.35	£7.50	£8.90		1" x 3/4"		£18.00**		
1/8" x 2"	£3.00	£9.50	£13.40		1-1/4" sq		£45.00**		
3/16" sq	£0.60	£2.00		£3.00	1-1/2" sq		£68.00**		
3/16" x 1/4"	£1.80	£2.20							
3/16" x 3/8"	£2.00	£3.10							
3/16" x 1/2"	£1.80	£3.80	£7.20						
3/16" x 5/8"	£2.10	£4.20							
3/16" x 3/4"	£2.00	£6.40	£7.40						
3/16" x 1"	£2.00	£4.80	£8.10						
3/16" x 1-1/4"	£2.60		£9.40						
3/16" x 1-1/2"	£2.80		£10.10						
1/4" sq	£1.40	£2.90		£4.80					
1/4" x 1/2"	£1.40	£5.20	£9.30						
1/4" x 5/8"	£1.25	£4.40	£10.00						
1/4" x 3/4"	£1.40	£6.50	£8.30						
1/4" x 1"	£1.40	£8.00	£9.70						

I have no 3/32" material left now, 2.5mm is the closest equivalent.

Cast Phosphor bronze (SAE 660, free machining)

Cut from 3" square x 10ft bars, so any size to order from this!

But – please be aware that the price of bronze has shot up in recent times and prepare yourself for a shock!

Square silver steel: 3/32" £3.20 per 13" length
 1/8" square silver steel is virtually obtainable but I do have a small stock at £6.00 per 13" length. When these stocks are gone I'll supply key steel as an alternative.

Hexagon	Steel	Brass	Colphos 90
<u>A/F</u>			
5/32"	£0.60	£1.50	
4/5mm, 3/116"		£5.50	
7/32", 5.5mm	£1.80	£6.40	
1/4", 6mm	£2.25	£7.40	£4.50
5/16", 8mm	£2.45	£2.80	£9.90
3/8", 10mm	£2.45	£9.00	£12.90
7/16"	£2.90	£11.30	
1/2", 12mm	£3.00	£13.50	
9/16"		£22.30	
1"		£40.00	
2ba	£1.15	£2.80	
3ba	£0.80	£2.80	
4ba	£1.50	£3.20	
5ba	£1.70	£2.40	
6ba	£1.50	£2.20	
7ba	£2.50		
8ba	£2.25	£2.60	
10ba	£2.25	£1.00	
12ba	£2.25	£1.80	

Some ba sizes are no longer available and it may be necessary to substitute the nearest metric equivalent.

Hexagon	Steel	Brass	Colphos 90
<u>A/F</u>			
5/32"	£0.60	£1.50	
4mm/5mm		£2.00	
3/16"	£1.80	£2.00	
7/32"(5.5mm)	£1.80	£2.40	
1/4"	£2.25	£3.20	
5/16"/8mm	£2.45	£3.80	
3/8"/10mm	£2.45	£6.00	
7/16"	£2.90	£8.30	
1/2"/12mm	£3.00	£8.50	
9/16"		£15.30	
Hexagon—BA sizes			
2	£1.15	£2.50	
3	£0.80	£2.80	
4	£1.50	£3.20	
5	£1.70	£2.20	
6 (5mm)	£1.50	£2.20	
7 (0.170")	£2.50		
8 (4mm)	£2.25	£2.60	
10 (3mm)	£2.25	£1.00	
12	£2.25	£1.80	
16		£7.00	

BA hexagon sizes are obsolescent and it may be necessary to substitute the nearest metric equivalent in some sizes.

MATERIALS - TUBE

All priced per foot ; ** sold by the inch, pro rata

Dia	Gauge	Brass	Gauge	Copper C106	Dia	Gauge	Brass	Gauge	Copper C106
1/16"	26	2.00	26	£2.70	7/8"	18	£5.50	20	£5.50
3/32"	24	£3.50		£2.70	1"			10	£ 24.00**
1/8"	24	£3.50	24	£2.70	1-1/2"			18	£16.50**
5/32"			24	£3.00				20	£13.20**
3/16"	22	£3.50	20	£3.60	1-3/4"	18	£18.00**	20	£21.80**
1/4"	22	£5.50	20	£4.00	1-7/8"		£27.00**	20	£36.00**
5/16"			20	£4.50	2"	18	£32.00	20	£27.80**
3/8"	20	£3.00	20	£5.00				16	£21.50**
1/2"	20	£4.50	18	£5.50	2-1/8"	18	£38.00*	18	£29.00
1/2" sq	20	£5.00			2-1/4"	16	£40.00**	16	£32.50**
5/8"			20	£6.00		20	£20.00		
3/4"	18	£5.50	20	£7.50	2-3/8"			16	£26.40**
5/8" sq	18	£7.50			2-1/2"	16	£19.50**		£28.50**
3/4" sq	16	£9.00			2-5/8"			16	£30.00**
1"	16	£12.00			3"	16	£28.00**	16	£24.00**

Stainless steel tube 1/8" OD annealed - £6.50/ft; 1/4" OD - £6.50/ft; 3/32" - £6.50/ft . 1" x 1-1/2" x 16g brass tube (for gas tanks) £60.00/ft

MATERIALS - BRASS STRIP & SECTIONS

Milled, not extruded, brass sections. Priced per nomir stock has come in - don't blame me!

	1/32"	1/16"	3/32"	1/8"	5/32"	3/16"	1/4"	5/16"	3/8"	1/2"	1/2"
1/64" strip	£2.25	£3.20	£3.40	£3.90		££4.10	£4.50	£5.00	£5.50		£6.50
1/32" strip		£3.20	£3.80	£8.50		£4.80	£4.20	£5.40	£5.90		£6.40
1/16" strip				£8.50		£11.00	£5.40	£7.40	£8.80		
Angle	£5.90	£9.80	£9.80	£11.80 (3 or 3.5mm)	£13.80 (4 x 2mm)	£13.50	£13.10	£16.50	£18.90		£20.00
Unequal angle					£12.00			(8 x 3mm) £16.50			
T section	£6.70	£8.50	£10.70	£14.00	£12.50	£13.80	£13.80				
Channel		£8.50	£11.50	£11.80		£11.50	£14.80	£14.80		£17.50	£23.50
H section	£7.50	£7.50	£7.50	£11.50	£11.50	£11.50					
Square channel	£7.00	£6.60	£9.90	£9.20	£10.00	£10.00	£12.50	£12.50	£14.50	£17.50	£30.40
I section		£7.50	£7.50	£10.50		£13.80					
Z section	£5.50	£5.50	£5.80	£5.80	£7.50	£8.40		£9.70			
Square	£3.50	£4.00	£5.50	£5.40	£6.00						
Half round		£1.90									
.006" tube	£8.00	£5.30	£6.00	£4.65	£4.65	£6.95					
.014" sq tube		£3.35	£4.70	£4.65	£6.00	£5.95	£3.00/ft	£7.00	£7.50		(13/32") £12.80
.028" tube				£3.70		£5.95	£6.55	£7.30	£8.55		
.014" sq tube		£4.90	£5.40	£5.80	£7.10	£7.90	£8.50				

Originally, I imported these sections from K & S of Chicago, but they have discontinued all but their range of tubing. I am now sourcing most (metric equivalent) sections from alternative suppliers but thin, straight brass strip is proving elusive to find as yet.

PIANO & BRASS WIRE

Price per yard

<u>Gauge</u>	<u>Diameter</u>	<u>Piano Wire</u>	<u>Brass Wire</u>	<u>Nickel Silver</u>
36g	.008"	**	£1.00	
33g	.010"	**	£1.40	
30g	.012"	**	£1.00	
28g	.015"	**	£1.90	
25g	.020"	£1.00	£1.40	
23g	.024"	£1.00	£1.50	£2.20
1/32"	.032"	£1.00	£1.50	
20g	.036"	£1.00	£1.50	£2.20
19g/1mm	.040"	£1.40	£2.00	£2.20
18g	.048"	£1.00	£2.00	
17g	.056"	£1.00	£2.00	
1/16"	.0625"	£1.00	£2.00	
5/64"/2mm	.078"	£1.50	£3.60	
3/32"	.094"	£1.50	£3.60	
1/8"	.125"	£1.50	£4.50	
5/32"	.156"	£2.00	£5.10	
3/16"	.1875"	£2.50	£6.00	
7/32"	.219"	£3.00	£6.90	

<u>Cat. No.</u>	<u>Free Length</u>	<u>ID mm</u>	<u>OD mm</u>	<u>Solid length</u>	<u>Load at solid length (g)</u>	<u>Material</u>
F470	14	3	3.5	3.3	280	CS
F471	12	2.2	2.9	4.5	200	CS
F472	13	4.2	5.2	5.1	310	CS
F473	12	2.7	3.4	3.4	290	CS
F474	14	2.5	3.5	5.1	1100	CS
F475	19	4.6	5.4	4.1		CS
F476	8	3.5	4.5	3.3		SS
F477	7	3.5	4.5	3.1		SS
		2.				

CS – Hard drawn carbon steel

SS – Hard drawn austenitic stainless steel

PB- Phosphor bronze.

All stainless steel springs are suitable for safety valves and other steam fittings where there is contact with water.

Carbon steel springs are £0.20 each, stainless steel are £0.80 each (J480/481 = 10p ea)

Cast Iron

Most sizes to order at the moment. I keep a selection of offcuts available —please ask if there is a particular size you require.

SECTION C - CUTTING TOOLS

DRILLS

Metric

HSS set:	1-13mm x 0.5mm, 29 piece in metal case	£32.00
HSS set:	1-10mm x 0.5mm, 19 piece in metal case	£16.00
HSS set	1-6mm x 0.1mm, 61 piece in metal case	£42.00

Individual

Individual drills are available in 0-05mm increments from 0.8mm to 5.0mm, and in 0.1mm increments from 5.0mm to 13mm

0.8 - 6.45mm :	£130ea	6.5 - 7.5mm :	£1.70ea	7.5 - 9.5mm :	£2.40ea
9.5 - 10.5mm :	£3.20ea	10.5 - 13.0mm :	£5.70ea		

Imperial

HSS set:	1/16"-1/4"	13 piece in dial case	£ 12.00
HSS set:	1/16"-1/2" x 1/64"	29 piece in metal case	

Individual

Individual drills are available in 1/64" divisions, 1/32"-1/2"

1/32" - 15/64" :	£1.15ea	1/4" - 19/64" :	£1.50ea	5/16" - 23/64" :	£2.30ea	3/8" - 27/64" :	£3.00ea	7/16" - 1/2" :	£4.60ea
------------------	---------	-----------------	---------	------------------	---------	-----------------	---------	----------------	---------

Number/Letter

HSS set:	1-60, 60 piece in metal case	£40.00
HSS set	61-80, 20 piece in plastic case	£ 9.00
HSS set:	A-Z, 26 piece in metal case	£27.00

Individual

All individual number drills (1-80) £1.50ea. All letter drills (A-Z) £3.50 ea

All the above prices are for reasonable quality drills. I can get top quality drills for those that want them, but they are typically around 3X the price.

Centre Drills

BS1 : £2.00; BS2 : £2.00; BS3 : £2.45; BS4 : £2.80; BS5 : £3.60 Set, BS1-5 : £11.00

Stub Drills (in ba tapping sizes, ea)

6ba (2.3mm) : £2.20; 8ba (1.8mm) : £2.20; 10ba (1.4mm) : £2.20; 12ba (1mm) : £2.20
3/32" : £1.00 (useful as small centre drills)

Countersinks

90deg, 3/8" or 3/8" shank : £4.60ea ; 4.3mm diameter : £5.60 ea.

Hand Reamers

Imperial

Set of 8, 1/16" - 1/2" £43.00

Individual Reamers, 1/32" increments, straight or taper shank

1/16" - 9/32" : £14.00; 5/16" - 31/64" : £17.00; 1/2" - 39/64" : £20.600
5/8" - 47/64" : £24.40 3/4" - 1" : £34.80

Metric

Set of 8, 1.5-12.5 £43.00

Individual reamers, 0.5mm increments, straight or taper shank

1-5mm - 7.5mm : £14.00; 8.0mm - 11.5mm : £17.00; 12.0mm - 13.5mm : £21.00

Tapered hand reamer (useful for easing bearing holes in frames etc) 5mm-12mm £5.50

SECTION D - FASTENERS

Taper Pins

Mild steel, metric : taper is 1/50; imperial taper is 1/48. Size is measured from small end. Price per 10.

2mm x 12	£2.50		
2mm x 16	£3.00	1/16" x 1/2"	£3.50
2.5mm x 25	£2.50	3/32" x 1½"	£4.25
3mm x 30	£4.20	1/8" x 1"	£2.90
4mm x 30	£2.90	5/32" x 1¼"	£4.25

Roll Pins

1/16" x 3/8" or 5/8" £2.00

Split Pins Zinc plated carbon steel.

<i>Dia</i>	<i>Length</i>	<i>Per 10</i>	<i>Per 20</i>
1/32" stainless st.	¼"	£2.50	£3.90
1/32"	¾"	£3.50	£6.00
3/64"	3/8"	£2.20	£3.10
3/64"	1"	£2.20	£3.10
1/16"	1"	£2.50	£4.50
5/64"	1-¼"	£1.50	£2.85
3/32"	1-½"	£1.60	£3.00
1/8"	1-¾"	£2.75	£4.20
5/32"	2"	£3.00	£5.50

Bondloc where available is the same stuff as Loctite but cheaper.

£7.90 per 10ml bottle

(Some types repackaged as 10ml bottles not available from manufacturer)

222	Low strength, threadlocking
242	Medium strength nut locker
243	Oil tolerant Medium strength thread locking and sealant
270	High strength thread locking (oil tolerant)
290	Medium strength capillary action threadlocker
542	Pipe thread sealer (£11.00)
572	Liquid gasket (£15.00)
601	High strength retainer
603	High strength oil tolerant retainer
620	High temperature retainer
638	High temp threadlock
641	Medium strength bearing fit (allows dismantling)
648	High temperature, oil tolerant high strength retainer

Medium/high viscosity/gel superglue	£3.90 (20ml bottle)
6ba ½" stainless allen socket cap screw	£0.65 ea
8ba x 5/16" or ¼" HT allen socket cap screws	£8.00 per 10
6ba x 3/8" HT allen socket cap screws:	£7.50 per 10
6ba x ½" HT allen socket c/s screw	£4.00 per 10
4ba x 3/16" HT allen socket c/s screw	£6.00 per 10
5/32" x ¾" steel rivet	£2.00 per 50 £3.50 per 100

Miniature countersunk brass woodscrews:

No. 0 x ¼"	Pk 10 £3.00
No. 1 x ¼" or ½", No. 2 x 1/2"	Pk 10 £2.50
Fine brass chain (15 links per inch):	£4.00 per yard (ideal for model load-securing chains)
(10 links per inch):	3.75/yd
40 mesh brass gauze	£4.50 per 6" square

FIXINGS (smaller quantities pro-rata +20%) (sh = 1 size smaller head)

<u>Hex head Steel</u>	<u>Per 50</u>	<u>Per 100</u>		<u>Per 50</u>	<u>Per 100</u>
2ba x 1/2"	£2.40	£4.40	8ba x 3/8"	£7.40	£10.20
2ba x 3/4"	£2.40	£4.40	8ba x 3/8" (s/h)"	£7.70	£14.60
2ba x 1"	£2.40	£4.40	-8ba x 1/2"	£6.60	£12.50
4ba x 1/2"	£4.00	£7.60	8ba x 1/2" (s/h)	£7.80	£12.50
4ba x 3/4"	£2.40	£4.40	8ba x 3/4" (s/h)	£8.80	£16.70
4ba x 1"	£8.00	£15.20	8ba x 1"	£6.30	£11.30
5ba x 1/2" (std or s/h)	£6.50	£11.50	8ba x 1" (s/h)	£7.10	£13.50
5ba x 1"	£6.30	£11.30	8ba x 1-1/2"	£9.40	£17.00
6ba x 1/4", (std or sh)	£6.50	£11.50	9ba x 1/2"	£7.10	£13.50
6ba x 1/2"	£5.10	£9.40	10ba + 3/8"	£5.10	£9.40
6ba x 1/2" (sm hd)	£7.50	£14.20	10ba x 3/8" (sm hd)	£7.50	£14.20
6ba x 11/16" or 13/16"	£4.80	£8.80	10ba x 1/2" (std)	£7.50	£14.20
6ba x 1"	£5.10	£9.40	10ba x 1/2" (sm hd)	£7.50	£14.20
6ba x 1" (sm hd)	£8.10	£15.40	10ba x 1/2" (std/sm)	£8.20	£15.60
7ba x 3/8" (std or sm hd)	£4.80	£8.80	10ba x 3/4"	£8.20	£15.60
7ba x 1/2" or 1"	£7.20	£13.50	12ba x 3/16""	£6.00	£11.40
8ba x 1/8"	£4.80	£8.80	12ba x 1/4"	£7.10	£13.50
8ba x 3/16"	£8.10	£15.40	12ba x 3/8"	£6.90	£13.00
8ba x 1/4" (std)	£5.80	£11.00	12ba x 1/2"	£7.70	£14.00
8ba x 1/4" (sh)	£5.40	£10.20	12ba x 3/4"	£7.70	£14.00
Countersunk Steel					
4ba x 1/2"	£4.40	£7.60	10ba x 1/2"	£4.50	£8.10
5ba x 1/2"	£5.80	£11.00	10ba x 3/4"	£4.80	£9.00
5ba x 1"	£5.80	£11.00	10ba x 1-1/2"	£6.50	£11.50
6ba x 1/4"	£4.00	£7.60	10ba x 2" (no slot)	£8.20	£15.609
6 x 3/8"	£4.40	£7.60	12ba x 1/4"	£3.50	£6.70
6ba x 1/2"	£5.40	£10.00	12ba x 3/8"	£5.50	£10.10
7ba x 3/16"	£4.40	£7.90	12ba x 7/16"	£4.00	£7.50
7ba x 1/2"	£6.10	£10.80	12ba x 1"	£4.50	£8.10
8ba x 1/8"	£3.80	£7.20	12ba x 1"	£6.50	£11.50
8ba x 3/16""	£4.00	£7.50	12ba x 2"	£8.20	£15.60
8ba x 1/4"	£4.00	£7.50	14ba x 3/16"	£4.50	£8.10
8ba x 5/16"	£4.00	£7.50	14ba x 7/16"	£6.10	£10.80
8ba x 1/2"	£6.80	£12.00	14ba x 1/2"	£6.10	£10.80
8ba x 1"	£5.40	£10.25	16ba x 1/8"	£4.40	£7.90
10ba x 1/8"	£9.50	£18.00	16ba x 1/4"	£4.40	£7.90
10ba x 1/4"	£6.50	£11.50	16ba x 3/8"	£5.50	£10.10
Round Head Steel					
4ba x 1/2"	£2.40	£4.40	10ba x 3/32"	£4.40	£7.90
5ba x 1/2"	£2.40	£4.40	10ba x 1/4"	£4.40	£7.90
6ba x 1/2"	£6.10	£10.80	10ba x 1/2"	£4.80	£8.80
7ba x 1/2"	£6.10	£10.80	10ba x 1"	£6.10	£11.60
8ba x 3/8"	£6.00	£11.10	12ba x 3/8"	£4.00	£7.60
8ba x 1/2"	£6.10	£11.60	12ba x 1/2"	£6.70	£12.10
Cheese Head Steel					
2ba x 1/2"	£2.40	£4.40	10ba x 1/8"	£3.50	£6.70
2ba x 1"	£3.20	£5.70	10ba x 1/4"	£3.80	£7.20
4ba x 1/2"	£2.40	£4.40	10ba x 7/16"	£3.50	£5.00
5ba x 1/8"	£3.20	£5.70	10ba x 1-5/16"	£5.50	£10.10
5ba x 1/2"	£2.40	£4.40	12ba x 1/8"	£3.80	£7.20
6ba x 1/4"	£4.80	£9.00	12ba x 1/4"	£3.80	£7.20
6ba x 1/2"	£4.80	£9.00	12ba x 3/8"	£4.40	£7.90
7ba x 1/2"	£4.80	£9.00	12ba x 1/2"	£3.80	£6.80
7ba x 1-1/4"	£6.50	£11.50	12ba x 1-1/4"	£6.70	£12.10
8ba x 1/8"	£3.20	£5.70	12ba x 2"	£6.70	£12.10
8ba x 1/4"	£3.50	£6.70	14ba x 1/4"	£3.80	£7.20
8ba x 5/16"	£3.50	£6.70	14ba x 5/16""	£6.10	£11.60
8ba x 1/2"	£4.50	£8.50	14ba x 1/2""	£6.10	£11.60
8ba x 1"	£9.40	£17.00	16ba x 1/8"	£4.40	£7.90
8ba 2"	£9.40	£17.00	16ba x 3/16"	£7.80	£14.10
9ba x 3/16"	£4.80	£9.00	16ba x 5/16"	£7.80	£14.10

Brass screws					
Hex head	Per 50	Per 100		Per 50	Per 100
	£4.90 per	£22.50			
	10	per 50			
2ba x 1"	£7.00	£12.60	10ba x 1/8"	£7.00	£12.60
4ba x 1/2"	£7.00	£12.60	10ba x 3/16"	£5.50	£10.10
5ba x 3/4"	£7.00	£12.60	10ba x 1/2"	£7.80	£14.10
4ba x 1-3/4"	£9.40	£17.00	10ba x 3/4"	£10.40	£19.80
6ba x 3/4"	£9.90	£18.50	12ba x 3/16"	£12.20	£23.80
7ba 1/2" sm hd	£9.90	£18.50	12ba x 1/2"	£8.00	£15.20
8ba x 1/4"	£11.40	£21.60	12ba x 3/8"	£11.90	£22.60
8ba x 1/2" (std or sm hd)	£7.80	£14.00	14ba x 1/4"	£14.50	£26.50
8ba x 1"	£11.90	£22.60			
Cheese Head					
4ba x 3/4"	£4.50	£8.50	10ba x 1/8"	£4.50	£8.50
5ba x 3/4"	£4.50	£8.50	10ba x 5/16"	£3.50	£6.70
5ba x 7/8"	£6.00	£11.00	10ba x 7/16"	£4.50	£8.50
6ba x 1/2"	£7.80	£14.00	10ba x 3/4"	£6.00	£11.40
6ba x 5/8"	£6.00	£12.00	10ba x 1-1/4"	£6.00	£11.40
6ba x 1-1/2"	£7.80	£14.00	12ba x 1/8"	£6.50	£11.80
7ba x 1/2"	£7.00	£13.30	12ba x 3/16"	£6.50	£11.80
8ba x 1/8"	£4.40	£7.90	12ba x 1/4"	£6.50	£11.80
8ba x 1/4"	£10.40	£19.70	12ba x 9/16"	£7.40	£14.00
8ba x 5/16"	£6.00	£11.40	12ba x 3/4"	£7.40	£14.00
8ba x 3/8"	£4.50	£8.50	12ba x 1"	£12.50	£23.00
8ba x 7/16"	£5.50	£8.50	12ba x 2"	£14.70	£27.00
8ba x 9/16"	£4.50	£8.50	14ba x 1/4"	£9.40	£17.00
8ba x 1-1/4" or 1-1/8"	£5.50	£10.10	14ba x 5/16"	£9.40	£17.00
9ba x 1/8"	£5.50	£10.10	14BA X 3/8"	£9.40	£17.00
9ba x 1/2"	£7.00	£13.30	14BA X 1/2"	£12.40	£23.50
10ba x 1/8"	£2.80	£4.90	16ba x 3/16"	£6.90	£13.10
10ba x 3/8"	£4.00	£7.50	16ba x 1"	£14.70	£27.00
Round Head			10ba x 3/32"	£3.50	£6.70
2ba x 3/4"	£4.50	£9.00	10ba x 1/8"	£3.80	£7.20
4ba x 1"	£3.20	£5.70	10ba x 1/4"	£4.00	£7.30
6ba x 1/2"	£4.00	£7.50	10ba x 3/8"	£4.40	£7.90
6ba x 3/8"	£4.50	£9.00	10ba x 7/16"	£4.40	£7.90
6ba x 1/2"	£4.50	£9.00	10ba x 1/2" no slot	£8.30	£15.70
6ba x 3/4"	£7.90	£14.10	10ba x 3/4"	£3.70	£7.00
6ba x 1-1/2"	£5.50	£10.10	10ba x 1-1/4"	£6.00	£11.00
8ba x 1/8"	£4.40	£7.90	12ba x 1/8"	£4.40	£7.90
8ba x 1/4"	£4.00	£7.50	12ba x 3/16"	£4.80	£9.00
8ba x 5/16"	£4.80	£9.00	12ba x 3/8"	£4.80	£9.00
8ba x 1/2"	£4.80	£9.00	12ba x 1/2"	£4.80	£9.00
8ba x 3/4"	£5.50	£10.10	14ba x 1/2"	£12.40	£23.50
Countersunk			10ba x 7/16"	£4.80	£9.00
4ba x 3/4"	£3.20	£5.70	10ba x 1/2"	£5.40	£10.00
5ba x 1/2"	£5.40	£10.00	10ba x 5/8"	£5.40	£10.00
6ba x 5/16"	£4.00	£7.20	10b x 1-1/8"	£6.00	£11.00
6ba x 1/2"	£7.50	£13.50	10ba x 1-1/2"	£6.90	£13.10
6ba x 1"	£5.50	£10.10	10ba x 1-3/4"	£6.90	£13.10
7ba x 1/2"	£5.50	1/2" £10.10	12ba x 1/8"	£4.50	£8.00
7ba x 1"	£7.50	£13.50	12ba x 1/4"	£4.80	£8.60
7ba x 1-1/2" or 2"	£12.40	£23.50	12ba x 7/16"	4.80	8.50
8ba x 1/8"	£4.00	£7.50	12ba x 3/4"	£5.40	£10.00
8ba x 1/4"	£4.00	£7.20	12ba x 1"	£5.40	£10.00
8ba x 1/2"	£4.00	£7.20	12ba x 1-1/4"	£6.90	£13.10
8ba x 3/4"	£4.80	£8.60	14ba x 1/8"	£5.40	£10.00
8ba x 1-1/8"	£6.00	£11.00	14ba x 3/16"	£5.40	£10.00
9ba x 3/16"	£9.90	£18.50	14ba X 1/2"	£6.90	£13.10
10ba x 1/8"	£4.00	£7.60	14ba X 1"	£8.00	£15.20
10ba x 1/4"	£4.00	£7.60	16ba X 1/8"	£6.90	£13.10
10ba x 5/16"	£4.50	£7.70	16ba X 1/4"	£6.90	£13.10
10ba x 3/8"	£3.50	£6.70	16ba X 1"	£14.70	£27.00

BA Nuts & Washers

Size	Steel Nut		Steel Washer		Brass Nut			Brass Washer	
	x50	x100	x50	x100	x50	x100	x50	x100	
2ba	£2.00	£3.80	£2.70	£5.10	£4.75	£9.00	£2.70	£5.40	
4ba	£2.70	£5.10	£2.70	£5.10	£5.00	£9.00	£1.50	£2.70	
5ba	£2.70	£5.10	£3.50	£6.80	£4.50	£8.50	£3.50	£6.80	
6ba	£3.50	£6.80	£2.70	£5.10	£3.80	£7.00	£2.70	£5.10	
7ba	£5.00	£9.00	£2.70	£5.10	£10.10	£19.00	£3.50	£6.80	
8ba	£3.50	£6.80	£2.70	£5.10	£3.50	£6.85	£2.70	£5.10	
8ba sm hd	£6.50	£11.70							
9ba	£10.5	£19.50	£2.50	£4.30	£10.10	£19.00	£3.50	£3.60	
10ba	£6.50	£11.70	£2.70	£3.60	7.50	£13.30	£2.70	£5.10	
10ba lock	£5.50	£10.40							
12ba	£6.50	£12.40	£3.50	£6.85	£6.50	£10.50	£3.80	£7.00	
14ba	£7.50	£13.30	£4.50	£8.50	£6.50	£12.30	£6.50	£12.40	
16ba	N/A	N/A	N/A	N/A	£21/00	£39.90	N/A	N/A	

Stainless Steel Nuts and Screws

size	C/H Screws	C/S Screws	Nuts
10BA X 3/16	£0.16	£0.25	£0.20
10BA X 1/4	£0.25	£0.25	
10ba x 1/2"	£0.25	£0.25	
10ba x 3/4"	£0.25	£0.25	
8BA X 3/8	£0.15		£0.20
8ba x 9/16"	£0.15		
8BA X 3/4	£0.15		
8ba x 1"		£0.30	
6BA X 1/2	£0.20		£0.15
6BA X 3/4 C/S		£0.25	
6BA X 1"	£0.90	£0.90	
6ba x 9/16"	£0.20		
6BA X 1 1/4"	£0.20		
6BA X 1 3/8" C/S		£0.20	
4BA 7/16	£0.15		£0.15
4BA X 1"	£0.90	£0.25	
4BA x 1-1/8" r/h	£0.25		
2BA X 1 1/2"	£0.35		£0.15

Studding (per ft)

	Steel	Brass
2ba	£3.30	£2.65
4ba	£4.50	£3.95
5ba	£5.00	£5.00
6ba	£5.50	£5.10
7ba	£6.50	£7.50
8ba	£9.50	£11.40
10ba	£12.00	£11.50

Grub screws (each)

2ba x 1/2"	£0.15
4ba x 5/16"	£0.35
4ba x 5/16"	£0.35
6ba x 1/4" or 3/8" allen	£0.60
Hex keys	£1.20
6ba steel slotted	£0.20
	£1.50
8ba allen	(£12.00/10)
Hex keys	£0.20
8ba steel slotted	£0.20
4ba x 1/4" brass slotted	£0.20
10ba x 1/8" brass or steel slotted	£0.20
	(£1.50/10)
12ba x 1/8" slotted brass	£0.25 ea (£2.00 per 10)
10ba x 1/4" ss slotted	£2.00/10
12ba x 1/4" ss slotted	£2.00/10
M2 x 2mm	£3.20/10

Rivets

<u>Snap head</u>	<u>Copper</u>	<u>Brass</u>	<u>Steel</u>	<u>Snaps</u>
1mm x 6mm"		£8.50		
1/32" x 1/4" or 3/8"		£7.50	£7.50	
3/64 x 1/4" or 3/8"			£6.90	£7.50
1/16" x 1/4"			£7.50	£7.50
			£7.50	£6.00
1/16" x 3/8"			£5.90	£7.50
1/16" x 1/2"				£4.50
3/32" x 3/8" Per 50)	£5.90		£4.00	
1/8" x 1/2" (per 50)	£3.00		£2.50	£5.10
1/8" x 3/4" (per 50)	£3.40		£3.20	£6.20
1/8" x 1" (per 50)	£6.00			
5/32" x 3/4"	£6.60		£4.00	
3/16" x 1/2"			£3.50	£6.20
3/16" x 3/4"			£4.00	£7.00
3/16" x 1"			£5.00	
			£7.50	
Countersunk				
1/32" x 3/8"		£7.30		
3/64" x 3/8"		£7.30		
1/16" x 1/2"		£7.50		

Miscellaneous Washers

Priced ea	<u>Copper</u>	<u>Red fibre</u>	<u>Aluminium</u>
5/32"-1/2" ID		£0.15	£0.10
3,4,5,6mm id.	£0.35		
8,10mm id.	£0.25		
12mm id	£0.25		

Self Tapping Screws

M1 x 3mm	M1.2 x 3mm	M1.4 x 3mm		
M1 x 4mm	M1.2 x 4mm			M2 x 4mm
M1 x 5MM	M1.2 x 5mm	M1.4 x 5mm		
			M1.7 x 5mm	
			M1.7 x 6mm	
				M2 x 8mm

All at £2.00 per 20

Metric Fastenings

I'm starting to stock more metric nuts and screws – please inquire.

SECTION E – STEAM FITTINGS

Pressure Gauges

½" pressure gauges 0-80, 0-100, and 0-120 psi, all at £34.00 ea. All have 5ba tail complete with union & nut

¾" pressure gauges 0-80, 0-100, 0-120 and 0-150 psi, all at £29.00 ea. All have 3/16" x 40tpi tail complete with union & nut.

1" pressure gauges 0-80, 0-100, 0-120 and 0-150 psi, all at £29.00 ea. All have 3/16" x 40tpi tail complete with union & nut.

Spare nut & cone for ¾" and 1" £2.20, for ½" £3.60. I also keep spare glasses for all sizes.

Stainless Steel and Phosphor Bronze Balls

Size	1/16"	3/32"	1/8"Ø	5/32"Ø	3/16"Ø	7/32"Ø	¼"	5/16"Ø	3/8"	7/16"	½"
Stainless ea.	£0.20	£0.20	£0.25	£0.25	£0.25	£0.25	£0.40	£0.45	£1.00	£1.90	£1.90
Per 10	£1.65	£1.65	£2.20	£2.00	£2.00	£2.00	£3.40	£4.00			
PB each	N/A	£0.35	£0.35	£0.60	£0.35	£0.65	£0.75	N/A	£0.75	£1.40	£2.50
PB per 10	N/A	£3.00	£3.00	£5.50	£3.00	£6.75	£7.90	N/A			

Viton Balls

Nitrile balls have been available for some time, but they are somewhat limited in their maximum operating temperature. This is well exceeded by Viton, they are slightly harder but not so hard as PB or stainless. If you are having trouble getting your valves to seal, these could be the answer! Now available in 3/32", 1/8" at £2.20 each, 5/32", 3/16" and ¼" at £2.60 each. Other sizes will be stocked if there is demand.

Unions, Union Nuts & Cones

Tube Diameter	Nuts/Cones		Double unions complete		Tees complete	
	Thread/Price ea.		Thread/price ea		Thread/price ea	
1/16"	3/16 x 40	£0.60	3/16 x 40		3/16 x 40	£5.00
3/32"	3/16 x 40	£0.60	3/16 x 40		3/16 x 40	£5.00
1/8"	¼ x 40	£0.75	¼ x 40		¼ x 40	£5.80
5/32"	¼ x 40	£0.75	¼ x 40		¼ x 40	£5.80
3/16"	5/16 x 32	£0.80	5/16 x 32		5/16 x 32	£7.80

1/16", M5 x 0.5 nuts : £0.70 (for either 1/16" or 3/32 cones) Banjos: 3/16" x 40 , 1/4" x 40 or ¼" x 32 : £4.00ea

NEW! 7/32 x 40 union nuts + 1/8" cones to match : £0.80 ea. Double union 6.50, , tees £7.50

O Rings

Both silicone and Viton O rings are available, silicone are more expensive but have better temp. resistance and are easier to fit.

Code	ID	OD	Thickness	Viton ea	Silicone ea
BS002	3/64"	9/64"	3/64"	n/a	£0.60
BS003	1/16"	3/16"	1/16"	£0.25	£0.75
BS004	5/64"	13/64"	1/16"	£0.35	£0.60
BS005	3/32"	7/32"	1/16"	£0.25	£0.75
BS006	1/8"	1/4"	1/16"	£0.40	£0.75
BS007	5/32"	9/32"	1/16"	£0.25	£0.60
BS008	3/16"	5/16"	1/16"	£0.25	£0.75
BS009	7/32"	11/32"	1/16"	£0.45	£0.45
BS010	1/4"	3/8"	1/16"	£0.25	£0.60
BS011	5/16"	7/16"	1/16"	£0.25	£0.50
BS012	3/8"	1/2"	1/16"	£0.25	£0.75
BS013	7/16"	9/16"	1/16"	£0.55	£0.75
BS014	½"	5/8"	1/16"		£0.75
BS110	3/8"	9/16"	3/32"		£0.75
BS111	7/16"	5/8"	3/32"		£0.75
BS112	1/2"	11/16"	3/32"	£0.25	£0.55
BS016	5/8"	3/4"	1/16"	£0.25	£0.75
BS113	9/16"	3/4"	3/32"	£0.38	£0.50
BS210	3/4"	1"	3/32"	£0.50	£0.65
2 x 1	2mm	4mm	1mm	n/a	0.60
4 x 1	4mm	6mm	1mm	£0.60	n/a
5 x 1	5mm	7mm	1mm	£0.60	£0.60
6 x 1	6mm	8mm	1mm	£0.60	n/a

1mm sizes are suitable for gauge glasses

PTFE Gasket	0.25mm	£6.00 per sq ft
	0.5mm	£7.50 per sq ft
Safety valves: "Tall" pattern, 1/4" x 40 or 32 tpi		£14.00 ea
"Express" pattern, 1/4" x 40 or 32 tpi		£15.00 ea
"Tall" pattern 5/16" x 40tpi		£18.00 ea
Clack valves: 3/16" x 40, 1/4" x 40 or 1/4" x 32tpi		£12.00 ea
1/4" Tube brush (brass or nylon bristle)		£3.00 ea
Goodall clack valves:		£ 7.50 ea (£12.00 with 90deg ENOT)
Water gauge (3/16" - or 1/4" x 40 fitting)		£32.50 ea
Bypass valve		£24.00 ea
Tender hand pump (1/4", 5/16" r 3/8" ram)		£34.00 ea
Carbon Fibre Wick - Gives an excellent blue flame		£3.00 per pack
50 mesh brass gauze for filters etc.		£5.50 per 6" square
CO2 Burner extinguisher (for meths burners)		£9.90 ea (includes 2 x 16g CO2 cyl)
Replacement 16g CO2 clys		£1.20ea
4mm clear gauge glass		£4.50/6"
5mm clear gauge glass		£4.50/6" length
5/6mm red stripe gauge glass		£5.50/6"
Steam Oil		
220 Grade (for Aster, Mamod etc.)	500ml:	£5.90
460 Grade, ideal for G1.	500ml: £8.90; 1L:	£15.50
680 Grade (higher viscosity)	1L:	£15.90
220 Grade Lubricating oil	500ml	£5.90

Clear Plastic Tubing.

Suitable for meths, heatproof in the ranges we need, good pressure resistance. Supplied in the following i.d.s:

3, 4, 5, 6mm; all sizes	£1.50 per yd
4mm silicone tubing	£4.00 per yd

Carbon Fibre boiler lagging.

Cross weave. Can be moulded, separated around bushes etc. £6.00/sq ft

Meths Wash Bottles

Safety non-drip 500ml washbottles appropriately labelled for methylated spirit – don't get your bottles mixed up! Each: £9.90

Hypodermic syringe – 5ml, ideal for emptying lubricators	Each:	£0.40
20 ml	Each:	£0.60
50ml for meths	Each:	£1.60
Needles (Blunt ended) 18g x 1-1/2"	Each:	£0.30

Live Steam Castings

GL-438	Steam Eccentrics	£5.95	per pair
GL-439	Steam Handwheels	£4.10	per pair
GL-440	Handpump bodies	£8.65	each
GL-500	Valve plate (steam passages cast in)	£4.50	each

BOILER MAKING

I can supply boilers in G1 sizes or similar made to a high standard at very reasonable prices, short delivery times and to more or less any design. We prefer to work to a drawing but in most cases we can get by if you just supply a sketch with the basic dimensions and position of fittings. Please call for a quote.

Gauge 1 miscellaneous

Gauge 1 Handrail Knobs: plain end for soldering or riveting (long or short)	£4.00 per 10
Gauge 1 handrail knobs : end threaded 10ba (long or short)	£4.90 per 10
10ba brass half nuts for handrail knobs,	£3.70 per 10
Handrails: 19g piano wire	£1.50 per yard
0.7mm stainless steel wire	£2.20/yd
1.0mm nickel silver wire	£2.20/yd
Delrin chain for power bogies	£4.50 per ft

Reinforced Fibre Cutting Disks

32mm diameter, for Dremel and similar tools, to fit 1/8" arbour. £2.50 per pack of 5

Hypodermic syringe – 5ml, ideal for emptying lubricators	Each: £0.40
20 ml	Each: £0.60
50ml for meths	Each: £2.20
Needles (Blunt ended) 18g x 1-1/2"	Each: £0.30
Small plastic funnels 3cm at top, 0.5cm at spout end	Each: £1.90

SECTION G – PAINTING SUNDRIES & PAINT

In the light of the increasing cost and difficulty of posting I have reluctantly decided to discontinue these as a catalogue item, though I'll continue to make them available at shows, please order in advance if there is a colour or size of tin you particularly require. I carry most of the steam and first generation diesel eras railway colours in gloss and sometimes in satin or matt as well, normally in 50ml tins, but I do carry some of the more popular sizes for larger models in 125ml tins, and lining colours in 14ml tinlets. Some colours are not necessarily available in all three alternative finishes. I also stock many items the range of varnishes and other products such as brush cleaners, matting agents and the like. I now carry most traction engine colours in larger tins.

SECTION H – KITS AND BITS

Live Steam Locomotive kits – 10mm scale

Paul Forsythe Designs

I offer basic materials kits for the Paul Forsythe designs, as for the Project. Please phone for details. Nickel silver plate is supplied as standard, but brass can be supplied if preferred – please specify when ordering. Cylinder kits are supplied with bronze blocks and pistons, valve rods, valve material, O rings etc. Cylinder castings can be supplied to order. Completed boilers are available to order with a rapid delivery time, as are ready made parts.

Model	Chassis	Cylinder(s)	Boiler	Platwork	Tender
Empire Maid	£16.00	£17.60	£35.00	£31.50	n/a
GCR 1B	£16.00	£17.60	£35.00	£31.50	n/a
GCR "Pom Pom" 0-6-0	£16.00	£17.60	£35.00	£27.00	£24.00
Johnson Tank	£15.50	£12.00	£35.00	£17.50	n/a
Director	£16.00	£17.60	£35.00	£31.50	£31.50
Caley 4-6-0	£16.00	£17.60	£35.00	£31.50	£31.50
HR Castle	£16.00	£17.60	£35.00	£31.50	£31.50
Jersey Lily	£16.00	£22.00	£35.00	£31.50	£31.50
Wainwright C	£12.00	£12.00	£35.00	£27.00	£24.00
Peppercorn K1	£16.00	£22.00	£35.00	£31.50	£31.50
Tilbury Tank	£16.00	£17.60	£35.00	£31.50	n/a
Wordsell R1	£16.00	£17.60	£35.00	£31.50	£31.50
LNWR Prince of Wales	£16.00	£17.60	£35.00	£31.50	£24.00

The Project



The items available for this model range from basic materials to ready-made cylinder, boiler, chassis and other components. An alternative design of boiler, by Paul Forsythe, is also available. As the cost of bronze has increased, I now supply a brass cylinder block as standard, but bronze blocks are available on request. Brass will work perfectly well, particularly if the piston is fitted with an O ring.

Basic set of materials, inc. Brass block, nickel-silver plate, 1/8" angle etc.	£180.00
Complete materials kit - Everything needed, including paint	£250.00
Frames and coupling rods, drilled with bushes	£48.50
Buffer beams, not fitted for axle pump	£26.00
Machined driving wheels and plain axles	£95.00
Crank pins plus bushes set of 6ea	£ 9.00
Brass axle bearings, set of 6 ea	£ 7.50
Crank axle	£29.50
Con rod, plus eccentric and adjustable valve strap complete	£50.00
Cylinder, brass block complete with O rings, crosshead, tube & drain cocks	£190.00
Valve rocking lever assembly	£25.00
Regulator with lubricator and pressure gauge pipe nipples & nuts	£35.00
Safety valve complete - 1/4" x 40 or 1/4" x 32	£15.00
Boiler feed check valve	£ 9.00
Chimney - lost wax casting, needs minor fettling	13.50
Dome - lost wax casting, needs minor fettling	£14.00
Buffers, each	£ 4.50
Smokebox, complete with door, ring, petticoat pipe	£35.00
Axle driven water pump	£100.00
Burner, including carbon fibre wick	£18.00
Lubricator & connections to cylinder	£35.00
Tender wheels, turned per 6, plus axles	£80.00
Tender axleguards, cast whitmetal (set of 6)	£20.00
Spirit cock	£18.50
Spirit tank materials, complete with spirit cock	£28.00
Spirit tank materials only	£9.50
Spirit tank, complete, with spirit cock	£48.00
Tender hand pump complete	£34.00
Tender filler cap	£ 4.90
Tender dome casting	£ 1.90
Tender vent castings x 2	£ 3.00
Tender handbrake/water scoop column (each)	£4.50
Spirit Sump	£ 5.00
Boiler to original design	£170.00
Boiler materials kit	£ 35.00
Boiler with Dee pattern backhead (better appearance, include reg/blower)	£190.00

ARMIG



ARMIG is the new gas fired 0-4-4T design from Dick Moger and Bob Gamble , based in either single or two cylinders

JTT supplies all the items needed to construct this model.

Designed to be easily built by newcomer to the hobby, the major components, in particular the CNC-machined cylinder blocks and crank axle, plus boiler, burner, and fuel tank are all available ready made . In addition, we also stock the chassis, wheels and body components and can supply these either as separate stages or as a complete kit. ARMIG mechanical components are available separately and are suitable for a wide variety of other inside cylinder locos, including Peter Korzilius's M7, N7 and E4. Transfers for the SECR era are available from G1MRA.

Cylinder set (2-cylinder):	£220.00	Safety valve	£15.00
Cylinder set (1- cylinder):	£135.00	Smokebox steam dryer coil	£19.00
Crank axle (2-cylinder)*:	£115.00	Lubricator + double union + banjo +pipe	£34.00
Crank axle (1 cylinder)*:	£45.00	Pressure gauge, banjo + pipe	£35.00
Connecting rods & eccentric straps (2-cyl)	£90.00	Front and rear boiler supports	£10.50pr
Connecting rod, eccentric & strap (1-cyl)	£45.00	Laser cut body kit	£106.00
Boiler, regulator & gas burner:	£120.00	Laser cut smokebox kit	£15.00
Burner, complete with jet	£32.00	Set of 4 turned buffers	£24.00
Boiler & burner materials kit (inc ready made bushes & burner jet)	£25.00	Dome, chimney, safety valve casting	£14.00 ea
Gas tank materials kit (inc ready made bushes & filler valve)	£12.50	Smokebox door set (includes turned door, hinges & dart)	£9.50
ENOT fitting, Goodall valve & spacer	£14.50	Westinghouse pump lost wax casting (not all had these)	£6.50
Gas tank, filler valve & regulator valve:	£40.00	Rolled boiler cladding & bands	£9.90
Laser cut frames (pre joggled)	£18.50	Smokebox lubricator lost wax castings	£5.00
Laser cut coupling rods	£5.50	Etched body kit only (ex-W&CW)	£145.00
Laser cut buffer beams	£5.90	Etched body kit (JTT/Orion)	£195.00
Laser cut frame stretchers	£6.50	Etched frames kit (includes frames, spacers, smokebox,) coupling rods etc)	£66.00
Laser cut bogie frames & stretcher	£4.20	Cast whitmetal steam reverser	£3.50
Turned wheels & plain axles	£115.00	Cast whitmetal tank fillers (Pr)	£3.50
Bushes, crankpins	£10.00	Cylinder lubricators (Pr)	£3.50

Walschaerts valve gear for 2-cyl ARMIG

We have now developed a fully working inside Walschaerts valve gear set for use with the ARMIG cylinder set. This valve gear will be capable of being easily reversed and will lend itself to sensitive radio control. Available to order, ca. £350.00 (but replaces Slip eccentric valve gear)

DEE



Another, rather more advanced design from G1MRA.

Material kit now available at	£ 18000
Boiler at	£240.00
Cylinder block complete	£220.00
Crank axle complete	£115.00
Water pump	£100.00
Scale safety valve (also suitable for ARMIG, Wainwright C)	£ 60.00

I am normally hold a stock of ready made components for this model, e.g. cylinder blocks, water pumps, crank axles, water pumps etc. Please call for availability.

ASTER PANNIER TANK CRANK AXLE

The axle is intended to be a straight replacement of the worn original, it is made from good quality steel with bearings from phosphor bronze. The webs have machined stop pin locations and are fitted to shouldered journals with silver steel pins. Connecting Rods are again of steel and form part the integral unit.

Fitting is straightforward, following the procedure detailed in the locomotives manual. The eccentrics should not be at all tight on the web diameter and the stop pins should be free to move and clear of the face of web. Observe position of stop pin location for orientation as it is possible to fit wrong way around.

Aster Pannier Tank Replacement Crank Axle



Price: £135.00

Excessive wear may be found on the stub axles on driving wheels, these were replaced on the test locomotive, axle boxes were reamed slightly oversize and pins made to suit, most wear being on the journal not the axle box. Can be supplied as an option, turned from Silver Steel.

GWR 56XX 0-6-2T TANK ENGINE

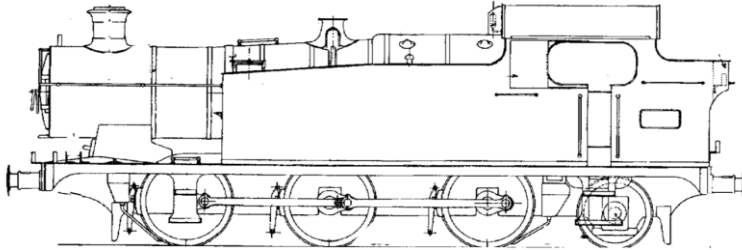

This locomotive has been re-engineered to provide a much more sophisticated but still reasonably priced large tank engine.

Features are:

1. ARMIG-pattern cylinders. Supplied as a ready to run cnc machined unit with ready made valve gear and cnc-machined crank axle
2. Project-type boiler for spirit-firing.
3. Enots type boiler filling. No external plumbing or hand pump.
4. Superdetailed etched nickel silver body
5. Working water tanks option if required
6. Gas fired option available

Prices (See ARMIG list for cylinders, crank axle, valve gear, gas boiler, burner, fuel tank):

Wheels (ready turned with crankpins, bearings etc.	£130,00
Boiler, regulator manifold, manifold, burner & fuel tank	Meths fired: £260.00
Etched body kit (3 sheets, including frames)	£325.00
Optional functional water tank etch	£145 .00
Chimney, smoke box door, top feed, tank fillers lost wax castings	£12.00 ea.
Buffers	£ 18.00

Stephensons valve gear

The fully working inside Walschaerts valve gear set for application with the ARMIG cylinder set is not suitable for some other applications, e.g. the 56XX and Q1. As an alternative, we have developed a version of Stephenson's valve gear for these kits and others. This is now available to order. Because assembling this gear requires quite precise work we are initially offering it on built-up chassis. This valve gear will be capable of being easily reversed and will lend itself to sensitive radio control. The price is £550.00 on top of the slip eccentric parts.

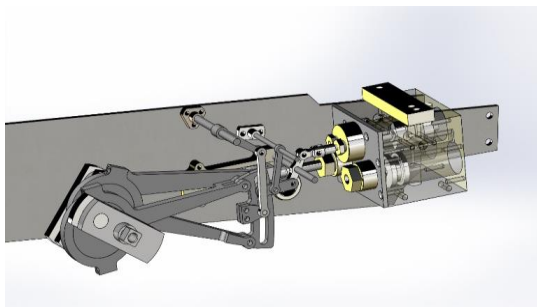

SR Q1 0-6-0 Tender Engine

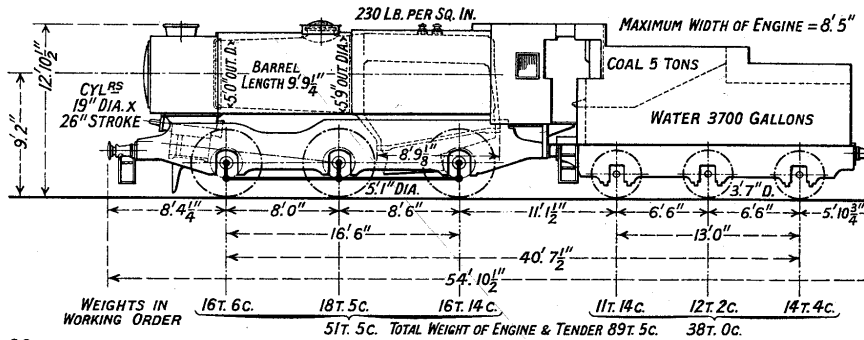

36

The second JTT locomotive kit is OVS Bulleid's Q1 0-6-0 tender engine. A wartime introduction, the Q1 was designed to produce a powerful locomotive with maximum route availability. Its unconventional appearance (Sir William Stanier is said to have remarked "Where does the key go?") was quite striking.

As with the 56XX this loco features a fully detailed etched nickel silver body. It is a spirit-fired design, in with a gas-fired option.

The loco driving wheels have been redesigned and are made of cast iron with an etch nickel-silver overlay to improve their appearance.

The boiler is intended to be refilled via an ENOTs valve, but there is room to fit a tender hand pump if preferred. We also offer an axle-driven water pump and bypass valve as an option.

The Stephenson's valve gear being developed for the 56XX tank is suitable for this model, giving full radio-controllability.

The etches, wheels, turned components and lost wax castings are available to those wishing to build an electric version.

Price list

Loco and tender kit, complete	£1600.00
Loco and tender etches	£ 550.00
Working Stephenson valve gear	£550.00
Axle driven water pump and bypass valve	£ 120.00
Tender hand pump	£ 28.00

New for Autumn 2022



B12/3 3 61572 is preserved on the North Norfolk Railway

JTT's next 10mm scale live steam locomotive kit will be the GER/LNER B12 4-6-0 in both GER (B12/1) and Gresley rebuilt B12/3 forms, designed by Tim Pringle and manufactured in laser cut brass and steel with lost wax brass castings. The model is designed for spirit firing but gas firing is an option.

The mechanical components are those from the highly successful "ARMIG" design, whilst the boiler design is based on that of the "Project", which has proved to be equally successful.

The kits will initially be available with slip eccentric valve gear, but it is planned to add a fully reversible valve gear as an option at a later date.

It is anticipated that the price of the initial spirit-fired, slip eccentric kits will be ca. £1800.00.



The GER 669 (LNER B12/1) will be available as a variant.

ARMIG Derivatives

I can now offer all the kits and components needed to complete the LSWR/SR M7, GER/LNER N7 and LBSCR/SR E4 designs by Peter Korzilius, including both standard ARMIG parts and also design-specific items.

JTT are collaborating with Peter Korzilius to offer our new inside Walschaerts valve gear on Peter's inside cylinder kits, from the second batch of E4 kits onwards.

N7/M7/E4 Castings: Chimney: £12.00; Dome: £14.00; Safety valve cover £9.00; Westinghouse pump £6.00; Steam reverser £3.50, Boiler clacks £5.50,- Cylinder lubricators £5.00, Vac pipes, steam heat hoses, air pipes all £4.50 set. M7 tank filler caps/cab rear windows £7.50 ea.

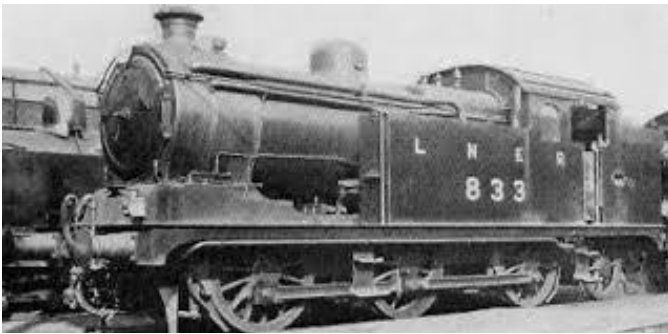

Electric Locomotive Kits

Steam Locomotives – 10mm scale

BR Britannia Class 7	Introduced in 1951 by British Railways, the 'Britannia' became the best known of the BR standard classes. This kit has an etched brass body with nickel silver chassis, numerous lost wax castings with the balance in white metal, and full brake gear to both engine and tender. Requires wheels, motor & gears to complete.	£875.00
BR 9F 2-10-0 (with BR 1D tender)	This kit has an etched brass body with nickel silver chassis, numerous lost wax castings and the remainder in white metal, and full brake gear to both engine and tender. Requires wheels, motor & gears to complete	£875.00
SECR H Class	Etched brass or nickel silver body with brass and whitemetal castings and brass sprung buffers. Requires wheels, motor and gears to complete.	£285.00
LNER Y6 Tram Engine	Better known as "Toby the Tram"! Etched body with brass and whitemetal castings. Designed to fit a playmobile chassis (not supplied) or requires motor wheels & gears.	£140.00

ACE Products Kits

I have been invited to become an agent for the ACE Products range of kits. The currently available range consists of:

LBSCR A1/A1X 0-6-0T	The model has been engineered from full size drawings in AutoCAD for an etched brass body in brass and with etched nickel silver for the chassis. The kit comes complete with different parts to enable the original Stroudley engine to be modelled as well as the engines later rebuilt to form the A1X variant with extended smokebox. Parts for the extended bunker of the engines working on the Isle of Wight are also included together with nameplates for these engines. The kit includes a pre-rolled boiler and all castings required to complete, but does not include motor , wheels and gears.	Price £225.00
LNER J50 0-6-0T	Originally designed for the GNR and further developed by the LNER this class worked across the LNER system. The model has been engineered from full size drawings in AutoCAD for an etched brass body in brass and with etched nickel silver for the chassis. The kit comes with different parts to enable the original J51 type or any of the subsequent J50/1-J50/4 types to be modelled and slows for the different bunkers and tanks to be fitted. The kit includes a pre-rolled boiler and all castings required to complete, but does not include motor , wheels and gears.	Price £225.00
SECR P class 0-6-0T	These locomotives were the SECR's intended replacement for various SECR steam railmotors but were found to be unsuitable for that role and were quickly relegated to shunting duties. Of 8 built 4 survived into preservation. The model has been engineered from full size drawings in AutoCAD for an etched brass body in brass and with etched nickel silver for the chassis. The kit includes a pre-rolled boiler and all castings required to complete, but does not include motor , wheels and gears.	Price £225.00
LBSCR C2X class 0-6-0	Coming soon	Expected price £299.00

Steam Locomotive Tender kits

British Railways Standard BR1 or BR1D tender	Etched brass, full rivet and brake gear detail with lost wax and whitemetal castings	£200.00
LNER A2 Rivetted Tender	Tender superstructure with outside chassis frames, A2 cab side sheets and smoke deflectors.	£86.00
LNER group standard Tender (6 wheels)	Tender superstructure complete with outside chassis frames and V2 cab (no roof) and footplate valances	£95.00

Steam Locomotive Etched Parts

LMS Black 5 Locomotive Parts	Cab sides, front and floor, front buffer beam, footplate (in 2 halves) sundry parts (no roof)	£32.00
LMS "Jubilee" Locomotive Parts	Cab sides, front and floor, front buffer beam, footplate (in 2 halves) and splasher tops (no roof).	£32.00
LMS Stanier 2-6-4T Locomotive & chassis Parts	Bunker & cab sides, front and floor, tank sides, front buffer beam, footplate (in 2 halves), sundry parts tender sides. Second etch includes chassis parts including cylinders & valve gear	£52.00
MR Johnson "Spinner" Locomotive Parts	Cab sides, front and floor, front buffer beam, footplate and splasher tops (no cab roof), tender sides	£32.00

Diesel Locomotives – 10mm scale

These kits are now available, normally to order although I'm gradually increasing stocks so most will be available ex-stock. They are also being upgraded with brass, rather than whitemetal, castings where appropriate and Fosmator bogies are available for most kits as an optional extra. These are priced at £180-00 per set for 6-wheeled bogies, £180-00 for 4-wheeled bogies and £230-00 for 8-wheeled ones. The kits are normally supplied with a flat-pack body, but a body-forming service is now available at an extra charge. Traditionally, the kits were supplied etched in nickel silver but most builders find the half-hard brass is easier to bend and this is the standard form now. Nickel silver is still available to order if preferred

BR Class 02 0-4-0DH	Etched kit for body with whitemetal castings. This loco is designed to fit onto a Playmobil 0-4-0 chassis. Some additional parts are needed to be made to complete the model.	£120.00
BR Class 08/9 0-6-00DE	This kit makes the earlier locos with wooden doors in the 13000 to 13365 number range. Modification is required to make the air braked version. Comes with Slaters wheels and axles.	£475.00
Br Class 20 Bo-Bo	Etched nickel silver body & chassis with white metal castings. Requires 3"7" wheels. Standard BR Type 1 mainly used on LMS freight in semi-permanent coupled pairs, and on channel tunnel workings.	£320.00
BR Class 31 Co-Co	Expected autumn 2022	
BR Class 33 Bo-Bo	Expected autumn 2022	
Br Class 37/1 Co-Co	Etched nickel silver body & chassis with white metal castings. Requires 3"7" wheels. The split headcode version of the standard BR Type 3 loco, used on all regions. Can be finished as either non-heat 37.0 or steam heat 37.1 versions. Includes all buffer beam fittings and couplings.	£385.00

BR Class 37/4 Co-Co	Etched nickel silver body & chassis with white metal castings. Requires 3'7" wheels. Makes the converted locos, 37.4 electric train heating fitted type as used on Scotrail and WR secondary passenger trains, or 37.5 Railfreight loco. Both locos have centre marker light panel and fixed beam headlight. Includes all buffer beam fittings etc. £405.00
BR Class 40 1-Co-Co-1	Etched nickel silver body & chassis with white metal castings. Requires 3'9" & 3'0" pony wheels. Original disc headcode version with later style radiator shutter. Used mainly on LM/ER freight and parcel duties, with all buffer beam detail. £425.00
BR Class 45/1 1-Co-Co-1	Etched nickel silver body & chassis with white metal castings. Requires 3'9" and 3'0" pony wheels. Electric train heating fitted version with last marker light format. Was last in use on LM/ER duties as Class 40. £425.00
BR Class 47 Co-Co (47/3, 47/4 & 47/7)	Builds 47.3, 47.4, and 47.7 versions in current configuration with marker light panel and fixed beam headlight. The standard BR Type 4 used throughout the country. 3ft 9" dia. wheels. £425.00
BR Class 50 Co-Co	Builds class in refurbished form with fixed beam headlight etc. Can be finished in large logo/NSE/civil or 3 tone grey. £425.00
BR Class 52 Co-CoDH Western	Etched nickel silver body & chassis with white metal castings. Requires 3'7" 4-hole wheels. WR type 4 hydraulic introduced in 1961 for express passengers, but used on freight by withdrawal in 1975. £320.00
BR Class 55 Co-Co "Deltic"	Etched nickel silver body & chassis with white metal castings. Requires 3'7" wheels. Covers this premier ECML passenger loco in its final form, with blanked off cab quarterlights and c1.50 style bogies. All detail on buffer beams. £425.00
BR Class 59 Co-Co	Etched nickel silver body & chassis with white metal castings. Requires 3'7" wheels. Foster Yeoman, ARC and National Power owned Type 5, built at General Motors USA, over 70ft long. A mammoth kit that includes full cab detail, name and number plates, all bits to build one of three types, 59/0, 59/1 Village Class or 59/2 Vale Class. £475.00

1/32" Scale Diesel Kits

I can now also offer the 1/32" scale model of the BR Class 08 "Gronk" by Orion Models. All etched kit, no whitmetal parts. Lost wax brass castings for the various buffer beam hoses.

Complete kit price £500.00, including motors, gears, screw couplings etc.

Narrow Gauge Steam Locomotives

We can offer some items, such as cylinder sets and burners for the "Wild Rose" design, and meths tank and burners for "Idris" – please call for info and prices.

10mm Scale Parts & Fittings

Diesel Locomotive Etched Parts

Etched Fold up gearbox for can motor	Each	£2.50
Cab Interior for Classes 37,40,45 & 55	Pair	£35.45
Diesel roof fan with support	Each	£2.50
Diesel Cab Seats - cast supports, no arms	Each	£6.50
Cab Handbrake Wheels	Pair	£1.90
Cab Interior for Class 20 Diesel	Each	£19.00
Cab Handwheels	Pair	£2.95
Diesel Chassis – nickel silver , with bearings	Pair	£47.25
Class 52 Cab Interior	Pair	£23.65

Cast Locomotive Parts

Britannia Whitemetal Castings

GC-058	BR 'Britannia' Smokebox door	Each	£10.00
GC-059	BR 'Britannia' Chimney	Each	£3.60
GC-060	BR 'Britannia' Dome	Each	£3.60
GC-061	BR 'Britannia' Trailing Bogie Axle Boxes	Pair	£10.00
GC-066	BR Britannia Backhead	Each	£21.25
GC035	BR Tender Water Scoop	Each	£5.60
GC063	BR Loco Shoes – handed in pairs	Set of 6	£10.25
GC067	BR Lubricators	Set of 2	£3.60
GC068	BR AWS Battery Box	Each	£3.60
GC069	BR Injector Steam Valves	Pair	£3.60
GC070	BR Mud Hole Doors	Set of 6	£4.35
GC216	BR Tender Axleboxes (Brit/9F)	Set of 6	£21.00
GC057	BR loco Springs	Set of 6	£14.20

LMS Whitemetal Castings

GC-109	LMS 'Black 5/Jubilee' Smokebox Door	Each	£6.50
GC-111	LMS 'Black 5/Jubilee' Dome	Each	£3.85
GC-112	LMS 'Black 5/Jubilee' top feed	each	£4.75
GC-113	LMS 'Black 5/Jubilee' Valve Guides	pair	£3.85
GC-194	LMS 'Black 5'/Jubilee' Chimney	each	£3.85
GC-198	LMS 'Black 5'/8F smokebox door and ring	each	£7.10
GC-214	LMS Black 5/ Jubilee Smokebox Saddle	each	£6.20
GC-131	LMS 'Princess' Chimney	each	£3.60
GC-132	LMS 'Princess' Dome	each	£3.00
GC-133	LMS 'Princess' Dome/top feed	each	£3.00
GC-134	LMS 'Princess' top feed only	each	£3.00
GC-135	LMS 'Princess' Safety Valves	pair	£2.65
GC-136	LMS 'Princess' Cylinder Covers	pair	£4.70
GC-137	LMS 'Princess' Valve Guides	pair	£3.85
GC-138	LMS 'Princess' Steam Pipes	pair	£4.75
GC139	LMS 'Princess' Lubricators	pair	GC-139 £7.70
GC-208	LMS 'Princess' pony truck axlebox	pair	£7.70
GC-143	LMS 'Duchess' single chimney	each	£2.95

GC-144	LMS 'Duchess' double chimney	each	£3.85
GC-180	LMS 'Duchess' Backhead	each	£16.55
GC-181	LMS 'Duchess' tender coal pusher	set	£24.00
GC-182	LMS 'Duchess' loco leaf springs	each	£2.10
GC-183	LMS 'Duchess' washout plugs	set of 6	£4.75
GC-184	LMS 'Duchess' mud hole door covers	Set of 4	£3.50
GC-185	LMS 'Duchess' pony truck casting - early style	each	£21.80
GC-186	LMS 'Duchess' pony truck casting - later style	each	£21.80
GC-187	LMS 'Duchess' steam pipe chest covers	pair	£6.65
GC-188	LMS 'Duchess' tender water filter boxes	pair	£3.85
GC-189	LMS 'Duchess' smokebox ejector set	Set of 2pc	£4.60
GC-190	LMS 'Duchess' cab injector and L/H valve	Set of 2 pc	£4.60
GC-191	LMS 'Duchess' Lubricators	Set of 4	£4.15
GC-202	LMS 'Duchess' smokebox door	each	£8.00
GC-203	LMS 'Duchess' tender rod covers	Pair	£3.60
GC-204	LMS 'Duchess' Snifting Valves	Pair	£2.95
GC-205	LMS 'Duchess' sandbox fillers	Set of 6	£4.75
GC-128	LMS Fowler 3500 gal. tender axleboxes	Set of 6	£16.80
GC-129	LMS Fowler 3500 gal. tender vents	Pair	£3.30
GC-140	LMS 4000 gallon tender axleboxes	Set of 8	£16.80
GC-141	LMS 4000 gallon tender water fillers	Pair	£4.25
GC-142	LMS 4000 gallon tender vents	Pair	£3.30
GC-192	LMS 'Coronation' single chimney	Each	£2.65
GC-193	LMS 'Coronation' double chimney	Each	£2.95
GC-218	LMS tender water scoop cover	Each	£2.35
GC-225	LMS Stanier Safety Valves	Set of 4	£2.95
GC226	LMS Duchess dome cover	Each	£4.20
GC237	LMS Duchess top feed cover	Each	£4.20
GC238	Duchess reverser stand	Each	£2.90

LNER Whitmetal Castings

GC-158	LNER A3 Single Chimney	Each	£4.15
GC-159	LNER A3 Smokebox door	Each	£6.50
GC-160	LNER A3 Washout plugs	Set of 6	£4.15
GC-161	LNER A3 Snifting Valve	Each	£2.15
GC-162	LNER A3/V2 Superheater Covers	pair	£2.95
GC-165	LNER A3 Smokebox Saddle	Each	£6.00
GC-166	LNER A3 Steam Pipes	Pair	£3.30
GC-167	LNER A4 Double Chimney	Each	£6.50
GC-168	LNER A3 Dome, early banjo type	Each	£3.55
GC-171	LNER A3/A4 Backhead	Each	£27.00
GC-175	LNER A4 Single Chimney	Each	£4.75
GC-177	LNER A3/A4 Early valve guide	Pair	£4.35
GC-178	LNER A3/A4 Late valve guide	Pair	£4.35
GC-179	LNER A3/A4 Cab Brake Standard	each	£4.50
GC-126	LNER P2 2-8-2 Chimney	Each	£4.75
GC-127	LNER P2 2-8-2 Smokebox Door	Each	£6.25
GC-172	LNER Tender water scoop cover	Each	£3.10
GC-173	LNER Tender water filler	Each	£2.65
GC-174	LNER Tender axleboxes	Set of 8	£21.85

GC-090	M.R. Johnson Tender Axleguards	Set of 6	£15.25
GC-092	M.R. Johnson Chimney	Each	£5.15
GC-093	M.R. Johnson Dome	Each	£5.15
GC-095	M.R. Johnson Smokebox Door	Each	£5.15
GC-096	M.R. Johnson Cab Reverser with handle	Each	£4.40
GC-117	'CR 123' 4-2-2 Chimney	Each	£4.20
GC-118	'CR 123' 4-2-2 Dome	Each	£3.70
GC-130	MR Bogie Tender Axleboxes	Set of 8	£20.50
GC-234	LNWR 'Coal Tank' chimney and base	Each	£4.60

Diesel Locomotive Whitemetal Parts

GC-048	Class 20 Diesel Bogie sideframes with end pieces only	Pair bogies	£39.50
GC-049	Class 37 Diesel Bogie sideframes with end pieces only	Pair bogies	£47.25
GC-050	Class 40 Diesel Bogie sideframes with end pieces only	Pair bogies	£47.25
GC-051	Class 45 Diesel Bogie sideframes with end pieces only	Pair bogies	£47.25
GC-052	Class 47 Diesel Bogie sideframes with end pieces only	Pair bogies	£59.00
GC-053	Class 55 Diesel Bogie sideframes with end pieces only	Pair bogies	£47.25
GC-054	Class 59 Diesel Bogie sideframes with end pieces only	Pair bogies	£63.00
GC-055	Diesel Brake Shoes	Set of 24	£13.15
GC-056	Diesel Bogie Air BrakeCylinders	Set of 12	£6.00

Lost Wax Locomotive Parts – Black 5/Jubilee

GL-321	LMS Loco buffers	Set of 4	£22.00
GL-322	LMS Black 5 Chimney	Each	£4.45
GL-324	LMS Black 5 Valve Guides	Pair	£7.50
GL-325	LMS Black 5/Jubilee Motion Bracket	Pair	£10.65
GL-326	LMS Black 5/Jubilee Smokebox Saddle	Each	£6.20
GL-327	LMS Jubilee/ pre-war Black 5 Chimney	Each	£4.75
GL-404	LMS Black 5/ Jubilee/Princess slidebars	Pair	£14.20
GL-405	LMS Black 5/ Jubilee Smokebox Door	Each	£6.85
GL-408	LMS Black 5/Jubilee Reverser	Each	£7.50
GL-430	LMS Black 5 dome and top feed	Each	£11.50
GL-437	Smokebox door ring	Each	£5.00
GL-459	Jubilee Valve Guides	Pair	£7.50
GL-450	Cylinder compression relief valves	Pair	£2.50

Lost Wax Locomotive Parts – LMS Princess/Duchess (*nickel silver)

GL-323	LMS 'Princess' Dome	Each	£4.25
GL-326	LMS Dchess LHS injector	Each	£8.85
GL-327	LMS Duchess RHS injector	Each	£8.85
GL-328	LMS 'Princess' Motion Brackets - also suit 2-6-4 tanks	Pair	£10.65
GL-385	LMS 'Princess' slidebars	Pair	£12.10
GL-386	LMS 'Princess' Crossheads	Pair	£10.35
GL-427	Rear Pony Truck Axleboxes (use GL-418 pony truck frame) also suit Duchess	Pair	£10.35
GL-330	LMS 'Duchess' Motion Brackets	Pair	£8.85
GL-331	LMS 'Duchess' Oil Boxes	Pair	£3.60
GL-332	LMS 'Duchess' Snifting Valves	Pair	£4.75
GL-333	LMS 'Duchess' Smokebox door dart	Each	£3.80
GL-334	LMS 'Duchess' tender rod cover handles	Pair	£5.30
GL-384	LMS 'Duchess' loco and tender buffers	Set of 4	£22.00
GL-402	LMS 'Duchess/Coronation' washout plugs	Set of 6	£5.35
GL-409	LMS 'Duchess' whistle	Each	2.95
GL-417	Double Chimney (also suit LNER A2)	Each	£5.95
GL-418	Rear Pony Truck Frame (also suit Princess)	Each	£5.95
GL-434	LMS Duchess Mud Hole Doors	Set 4	£4.45

GL-434	LMS Duchess Mud Hole Doors Tender Water Sieves, handed, suitable for Aster Locos	Set 4	£4.45
GL-465*	compete lwith bolt and fixing plate	Pair	£24.15
GS500*	LMS "Duchess" crossheads	Pair	£11.90
GS501*	LMS 'Duchess' slide bars	Pair	£13.25
GS502*	LMS Black 5/Jubilee slide bars	Pair	£10.55
GS503*	LMS Black 5/Jubilee/Stainer 2-6-4T crossheads	Pair	£8.65
GS512 *	LMS Duchess radius links	Pair	£5.90
GS513 *	LMS Princess & Stanier 2-6-4T slidebars	Pair	£11.25
GS514*	LMS Duchess/ Princess/2-6-4T return cranks	Pair	£5.85
GL467	LMS Duchess cylinder snifting valves	Pair	£4.30

Lost Wax Locomotive Parts

GL-360	A3/V2 Smokebox superheater covers	Pair	£6.45
GL-361	A3 Single Chimney	Each	£4.75
GL-367	A3/A4 Motion Brackets	Pair	£10.35
GL-368	A3 Smokebox Door	Each	£7.10
GL-369	A3 Smokebox Door Ring	Each	£5.15
GL-372	A3/A4 Cab Reverser Stand	Each	£3.60
GL-373	A3 Saddle Front	Each	£4.45
GL-374	A3 Cylinder Rear Cover	Pair	£7.70
GL-375	A3 Dome, early type	Each	£7.20
GL-376	A3 Dome, later banjo type	Each	£12.10
GL-428	A4 Single Chimney	Each	£6.50
GL-429	A3 Lubricators - 4 small (also suit A2)	Set of 4	£5.30
GL-431	A3/A4 Slide Bar Brackets	Pair	£5.95
GL-432	A3 Cylinder Drain Cocks	Pair	£4.75
GL-433	A3 Safety Valves	Pair	£4.15
GL-441	A3/A4 Cartazzi Axleboxes handed	Pair	£18.60
GL-442	A4 Double Chimney	Each	£10.05
*GS503	LNER valve spindle guides	Pair	£16.50
GS504*	LNER slidebars	Pair	£16.90
GS506*	LNER A3/A4 return cranks	Pair	£5.85
GS507*	LNER A3/A4 Radius links	Pair	£6.20
GS508*	LNER A3/A4 crossheads	Pair	£13.90
GS509*	WD 2-8-0/2-10-0 Slidebars	Pair	£10.05
GS510*	WD 2-8-0/2-10-0 Crossheads	Pair	£7.55
BR13	BR 'Britannia' Combination Injector	Each	£16.00
BR21	B. R. Britannia/9F Cab Reverser	Each	£5.95
BR20	B. R. Britannia/9F Cab Regulator	Each	£4.60
BR19	B. R. Britannia/9F Manifold	Each	£5.00
BR18	B. R. Britannia/9F Large Vacuum Ejector	Each	£7.10
BR17	B. R. Britannia/9F Valve Gear Lifting Arm and Ring	Pair	£7.40
BR14	B. R. Britannia/9F Steam Sanders Pair		£6.15
BR5	B.R. Britannia/9f safety valve	Pair	£5.40
BR7	B.R. Britannia/9f cylinder drain cocks	Pair	£7.20
BR 15	B. R. Britannia carriage warming valve	Each	£4.75
BR16	B.R. Britannia/9f cab fittings	Each	£4.00
BR12	B. R. Britannia/9F Boiler Feed Clacks	Pair	£8.90
BR11	B. R. Britannia/9F Injector Water Valve	Each	£4.75
BR10	B. R. Britannia/9F Ejector Shut off Valve	Each	£4.75
BR6	B.R. Britannia/9F valve spindle guidess	Pair	£12.50
BR9	B. R. Britannia/9F Live Steam Injector	Each	£5.15
BR6	B. R. Britannia/9F Valve spindles	Pair	£7.35
BR4	B. R. Britannia/9F Slide Bar Brackets	Pair	£13.00
BR3	B. R. Britannia/9F Valve Guides	Pair	£14.20
BR2	B. R. Britannia/9F Crossheads	Pair	£13.90
BR1A/B	B. R. Britannia/9F Slide Bars	Pair	£19.95
BR22/23	B.R. Britannia/buffers	Set of 4	£22.00
BR24	BR blowdown valve	Each	£2.50

Detail Packs for 9F/Britannia

Builders of the Model Engineers Laser live steam Britannia or 9F may be interested in the various superdetailed lost wax components that we supply for our electric kits. A detailing pack is available for £125.00 and includes sidebars and crossheads, or individual items may be purchased from the list of BR1-BR23 above.

Lost Wax Locomotive Components -General

GL-364	LNER Loco Brake Shoes		£11.80
GL-365	LNER Tender Brake Shoes	Set of 6	£16.55
GL-366	LNER Smokebox Elbow	Each	£2.55
GL-370	LNER Loco Driver Leaf Springs	Each	£4.15
GL-371	LNER Tender Brake Standards	Set of 4	£5.20
GL-378	Link supports	Set of 8	£63.00
GL-379	LNER Valve Guides, early type	Pair	£9.95
GL-380	LNER Valve Guides, later Stanier type	Pair	£9.95
GL-381	LNER Loco Buffers	Pair	£9.00
GL-382	LNER Tender Buffers	Pair	£9.000
GL-398	LNER 'P2' motion bracket	Pair	£6.65
GS-509	W.D. 2-8-0/ 2-10-0 Slidebars	£10.05	per pair
GS-510	W.D. 2-8-0/ 2-10-0 Crossheads	£7.55	per pair
GL-399	Loco cab handwheels	Pair	£3.60
GL-401	Long Oval Diesel Buffers	Set of 4	£21.85
GL-406	MR Safety valve lever only	Each	£2.95
GL-407	GWR 'King' Bell & Bracket	Set	£5.30
GL-412	Round Headed Diesel Buffers	Set of 4	£22.05
GL-416	GWR Castle Chimney	Each	£7.30
GL-419	GWR 'Castle' safety valve	Each	£5.65
GL-420	Standard long horn guide	Pair	£7.10
GL-422	Short Horn Block Guides	Pair	£7.10
GL-423	MR 4F Tender Axleboxes	Set of 6	£28.35
GL-424	LMS Streamlined Coronation Single Chimney	Each	£3.35
GL-425	MR Boiler Clacks	Pair	£5.50
GL-435	M. R. Whistle	Each	£3.15
GL-436	M. R. Salter Safety Valve set	Each	£3.75
GL-444	M.R. Safety Valve Cover	Each	£5.50
GL-449	NYC 'Hudson' Loco Brake Shoes	Pair	£3.35
GL-455	Control air pipe diesel locomotive multiple working (paint white)	Pair	£7.10
GL995	Oiler boxes & feed pipes	Set of 4	5.90
GL-456	Air Pipe - locomotives and stock. (Paint red- brake pipe, paint yellow - main reservoir pipe)	3 Pairs	£10.50
GL-457	Older style steam stock steam pipe	Pair	£7.10
GL-458	Universal Vacuum Pipe - under buffer beam type	Pair	£6.50
GL-462	LNER D16 Safety Valve Levers	Pair	£2.95
GL-463	General Brake Standard	Each	£3.50
GL-466	Southern Region Tender Axleboxes	Set of 6	£28.35
GL-467	Diesel Air Pipes - handed	Pair	£4.15
GL-996	Loco injector	Each	£4.95
GL998	Diesel air horn	Pair	£3.50
GL997	Steam loco whistle	Each	£1.00
GL996	Smokebox door dart	Each	£1.25
GL999	LMS Smokebox ejector	Each	£5.95
GL1000	19 th C GNR Loco buffers	Set of 4	£22.00
GL1001	Diesel speedometer boxes (bogies & body)	2 Pairs	£7.00
GL1002	Smokebox lubricators	Pr	£4.50
GL1003	Ross "pop" safety valves	Pr	£4.50

Carriage Kits

The following range of ex-W&CW Kits is available:

Pre-BR Coaching Stock

LNWR 50ft Full Brake	Etched brass with whitemetal castings	£195.00
LNWR Thompson BG Deal Planked	Etched brass with whitemetal and lost wax brass castings and aluminium roof	£195.00

BR Mk 1 Coaches & Vans

These etched nickel silver kits come with full chassis buffer beam and roof detail, with a choice of whitemetal B1 or Commonwealth bogies, and wheels. Types available are:

Open First (FO)	Corridor First (FK)	Brake Second (BSK)
Open second (SO)	Corridor Second (SK)	Tourist Open second (TSO)
Corridor Composite (CK)	Restaurant Buffer (RBR)	Miniature Buffet (RMB)
Restaurant open (RSO)	Sleeper Third (SLT)	Full Brake (BG)
Sleeper First/Second	General Utility Van (GUV)	Covered Carriage Truck (CCT)

All are £235.00 each, apart from the CCT which is £135

Carriage Components

COACH BOGIE KITS.

Coach bogie kits are available to suit the following cast whitemetal sides and have been redesigned to incorporate a sprung bolster plank.

Castings available:

BR Mk 1	BR Commonwealth	LMS 6-wheeled
GWR 9'	GWR 7'	GWR 9' Dreadnought
Fox pressed steel 4 wheeled	Fox pressed steel 6-wheeled	GN/GCR 6-wheeled
LMS	Pullman	SR Maunsell
LNWR Gresley light type	LNWR Gresley Heavy type	LNWR Gresley 10ft artic type

Kit complete with wheels and ball race bearings	£55.00 per pair
Kit complete with wheels and nylon bushes (BR Commonwealth)	£70.00 per pair
Kit complete as above for 6 wheeled bogies	£70.00 per pair
Bogie side castings:	£ 24.00 per set of 4

All prices are per pair of bogies, i.e. one coach-worth

Brass axle bearings: Pk of 8 £2.00

Wheels: 3'1" wagon disk or 3'1" nspoked wagon: £5.00 per axle
 : (all-metal, insulated)coach disk (3'9") : **£6.50**
 : (plastic centre, steel tyre) coach disk (3'9") : **£5.50**

Roofs

Suitable for most designs of carriage with elliptic roofs without domed ends, these are machined from lime wood and are dimensionally stable and straight and true, requiring only light sanding to finish them - £14.00 each. Currently available : GWR corridor stock, LNER Thompson, SECR birdcage.

Wooden seating strip

Approx 1M: £5.00

Seated/Standing Figures REDUCED - Ready painted, pack of 8 assorted seated figures £6.00/pack, 10% discount for 3 or more packs

Whitemetal Carriage Parts

GC-023	Buckeye Couplings	£5.15	per pair
GC-043	BR Mk. 1 bogie - no wheels	£29.50	per pair
GC-047	BR Commonwealth Bogies - no wheels	£42.50	per pair
GC-073	Coach Dynamo – LMS/BR Type	£1.60	each
GC-075	Coach shell Vents	£5.75	per 12
GC-079	Coach Torpedo Vents	£6.00	per 10
GC-097	Coach Table and Legs	£4.40	per set
GC-098	Coach Double Seat Ends	£6.00	per 4
GC-102	BR Coach Vacuum Cylinder	£3.60	pr
GC-103	BR Coach Voltage Regulator + Fuse Box	£3.60	set
GC-145	Long Battery Box	£4.15	each
GC-148	LNER Coach Air Tanks with Brackets	£5.25	per pair
GC-212	Coach end jumper leads	£4.75	per 4
GC-219	LNER Coach Dynamo	£2.95	each
GC-221	BR MK I Coach Periscope	£1.95	each
GC-223	LNER Bow Ended coach end	£12.35	per pair
GC-226	LMS 'Paletorpes' Sausage van ends	£11.85	per pair
GC-300	21" vacuum cylinder	£3.50	Per pair
GC-301	18" vacuum cylinder	£3.50	Per pair
GC801	ETH fittings set	£3.50	Per set

Lost Wax Carriage Parts

GL-335	Table Lamps	Each	£2.10
GL-336	Pullman square toilet window	Pair	£9.00
GL-337	Pullman oval toilet window	Pair	£9.00
GL338	Saloon window lights	Set of 8	£12.50
GL-343	LNER 'Gresley' Underframe Turnbuckle	Set of 4	£6.00
GL-344	LNER 'Gresley' Corridor Coach Buffers	Set of 4	£18.00
GL-445	LNER type Long Grab Handles	Pair	£3.25
GL446	LNER Gresley "Suburban" Coach Buffers	Set 4	£18.00
GL-446	LNER Guards Door Handles	Pair	£3.25
GL-447	BR Thompson P.B.V. Buffers	Set of 4	£21.85
GL-468	BR MK 1 coach door commode handles	Pair	£2.35
GL991	Large torpedo vent	Pk 8	£6.40
GL992	Jumper cables	Pk 4	£4.50

GWR Carriage Parts

I can now offer a range of lost wax brass castings for Dean-era GWR carriage fittings, although of course many items will be usable for carriages of later eras or for carriages of other companies.

GW1.	Gas tank fittings	set	£6.00
GW2.	Gas tank supports	pair	£7.50
GW3.	Body end/roof communication cord fittings	set	£4.50
GW8.	Dynamo body	each	£4.50
GW9.	Gas tank ends	pair	£5.50
GW10.	Dynamo bracket	each	£3.50
GW11.	Vacuum cylinder V hangers	pair	£4.50
GW13.	Dynamo end	each	£3.50
GW14.	Brake shaft	pair	£6.00
GW17.	Round buffer heads (nickel silver)	set of 4	£8.00
GW18.	Underframe trussing turnbuckles	set of 4	£4.50
GW19.	Long tapered buffer stock	set of 4	£12.00
GW20.	Square shank buffer stock	set of 4	£12.00
GW21.	Oval buffer heads (nickel silver)	set of 4	£8.00
GW23.	Underframe queen posts	set of 4	£4.50
GW24.	Buffer beams	pair	£16.00
GW25.	Door ventilators	set of 8	£12.00
GW26.	Gas lamp interior (whitemetal)	set of 4	£7.00
GW27/30.	Gas lamp exterior cover & base (whitemetal)	set of 4	£7.00
GW28.	Gas lamp exterior cover & base (brass)	set of 4	£9.00
GW29.	Vacuum cylinder (whitemetal)	pair	£3.50
GW31.	Gas lamp interior (brass)	set of 4	£10.00
GW32.	Battery box	pair	£12.00
GW33.	Large vacuum cylinder	pair	£5.50
GW34.	BS gangways	pair	£40.00
GW35.	Door commode handles	set of 8	£9.00
GW37.	Cranked lamp iron	set of 4	£6.00
GW38.	Door handles	set of 8	£4.50
GW42.	Vacuum pipe swan necks with hoses	pair	£6.00
GW46.	Body end steps	set of 4	£4.50

Resin Wagon Kits (10mm scale)

Resin cast wagon which come complete with sprung wheels, buffers, brake gear, couplings and a sheet of transfers .

Prices are:	open wagons (all four types)	£60.00 each
	Box vans (2 types)	£70.00 each
	Long wheelbase open wagon	£65.00 each
	LNER fish van	£85.00 each

These detailed Bodies are complete and do not need assembly.

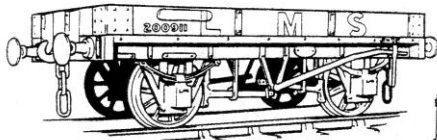

- 1 Plank Open - Fixed Side
Suitable for LSWR, LMS Versions

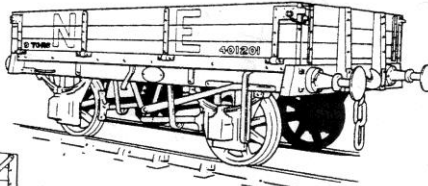

- 3 Plank Open - Drop Side
Suitable for LSWR, LMS, LNER/GN Versions

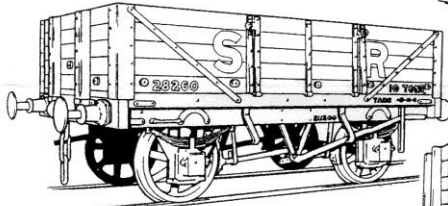

- 5 Plank Open - Side Doors
Suitable for SR, LMS, LNER, BR Versions

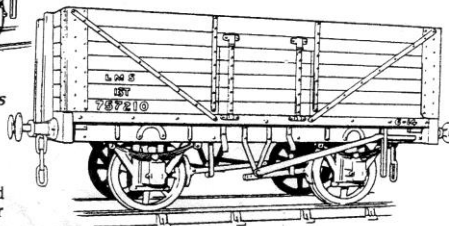

- 7 Plank Open - Mineral Wagon
Suitable for SR, LMS, LNER/GN Versions

Gauge One Wagon Bodies are detailed cold cast resin models. Each is supplied with a floor ready to be fitted and with holes for the fittings marked ready to be drilled.

The Bodies need painting in the authentic regional colours. A Transfer sheet is included with markings for a selection of regions. Each body comes with a specifications sheet giving details of history, running numbers and colour schemes.

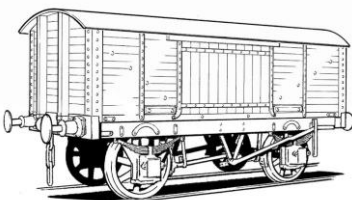
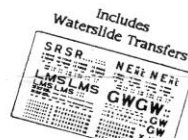

LBSCR / SR box van



Sealion bogie ballast hopper , built by Pat Honey

Etched Brass Wagon Kits

Steam Era

GWR/BR Macaw 'B' Bogie Bolster	Etchings only for body and underframe - use Tenmille bogies, stanchions and 3'1" 3-hole or spoked wheels to complete.	£105.00
GNR/LNER 8T Dropside 'Colwich' open wagon	These wagons were built by the GNR and passed into LNER hands. They were unusual in that the single wheel brakes were both to the left hand wheel as you viewed from the side although the brake levers were both at the same end.	£68.25
GN/LNER 9T 4 Plank Open Wagon	These wagons were built by the GNR and passed into LNER hands. They were unusual in that the single wheel brakes were both to the left hand wheel as you viewed from the side although the brake levers were both at the same end.	£68.25
GN/LNER 8T 4 Plank Bow Ended Open Wagon	These wagons were built by the GNR and passed into LNER hands. They used a timber pole placed from end to end to support a wagon sheet over the load.	£68.25
Metropolitan 12T Small Brake Van		£99.75
LMS/ BR 25T Ballast Hopper Wagon - Diag 1800	Leeds Forge built 20 of these hoppers to lot 371 in 1928. Lasted to BR days.	£89.25
LNER/BR 25T Ballast Hopper Wagon	Again built by Leeds Forge between 1926 and 1937, these engineering hoppers lasted well and some were still at work in Scotland in the early 1970's.	£89.25

Diesel Era Wagons

Independent Snow Plough	This kit is based on unit no. ADB 965307 of Bescot Depot, West Midlands and is typical of the type allocated to several systems.	£80.00
Diesel Brake Tender	Etched brass body with white metal castings. Standard round bodied design with LNER bogies, introduced in 1964 for use with vac fitted freights on classes 25,37,40 & 45. Kit requires paint and transfers to complete.	£100.00
SR/BR Sealion bogie ballast hopper	Etched brass body with whitmetal bogies and castings, comes with etched brass wheel inserts to represent modern wheels	£140.00
Grampus Type ZBV Spoil and sleeper wagon	Most numerous Departmental type - seen everywhere and now appearing in grey and yellow livery.	£92.40

Unless otherwise stated, all etched wagon kits are complete with all cast components and the appropriate wheels, buffers and couplings.

Lost wax castings for Locomotives & Carriages

Commented [RM4]:

Item	No. Pk	Price
Boiler clack valves (round or square flange)	2	£5.50
Lamp iron (for horizontal surfaces)	8	£4.50
Lamp iron (for vertical surfaces)	8	£4.50
Lamp iron for brake vans	4	£4.00
Westinghouse pump	1	£6.50
Set of 3-link couplings	1pr	£4.00
Set of Instanter couplings	1pr	£4.50
Set of screw couplings	1pr	£12.00
Brass door handles (3 different types)	8	£4.50
Brass commode handles (7 types)	8	£9.00
Coach end steps	8	£6.50
Locomotive or tender brake shoes & hangers set	4	£6.00
Wagon brake set	1	£12.00
LMS loco Sprung buffers	4	£18.00
Short brake handle	2	£3.50
Wagon axleguards & sprung axleboxes	4	£18.00
4/6wheel carriage/van axleguards and sprung axleboxes	4	£18.00
Van spring damper/shock absorbers	8	£6.50
Loco lamps - square body (BR, GWR, LMS)	2	£4.50
Loco lamps – round body (LNER, SR)	2	4.50
Sprung wagon buffer three rib with step	4	£18.00
Sprung wagon buffer round base short (SR)	4	£18.00
Sprung wagon buffer round base long	4	£18.00
Sprung buffer round base long (SR coach)	4	£18.00
Sprung buffer SR brake van square base	4	£18.00
Sprung Oleo diesel loco buffers	4	£18.00
Sprung Oleo wagon buffers	4	£18.00
Open wagon door stop	2	£1.00
Smokebox door set (dart handles, hinges and hinge blocks)	1	£5.50
Loco or tender hand brake column	1	£4.50
SR route Indicator discs	4	£4.50
Communication cord roof boxes	1set	£2.50
Coach vacuum cylinders 21"	2	£6.00
Goods van door handle	2	£1.50
1/8" brass bearings	8	£3.50
Pointwork bellcranks	4	£3.00
Loco whistle	1	£1.00
Wagon/Van spring end shock absorbers	8	£8.00
Steam heat pipes	2	£3.50
Loco/Wagon vacuum pipes	2	£3.50
Lever reverser	1	£5.50

Locomotive Carriage & Wagon Detailing

Lost Wax Castings

Lost Wax Castings
- in Brass -

GRAB HANDLES

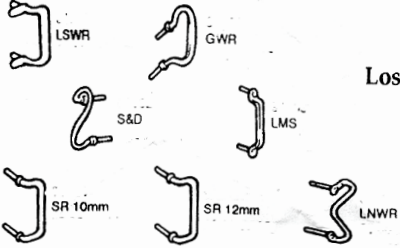

DOOR HANDLES



COACH FITTINGS

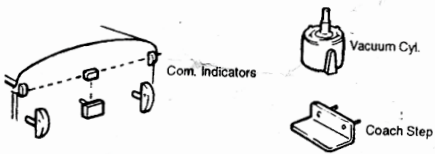

BRACKETS



LAMPS



BRAKES

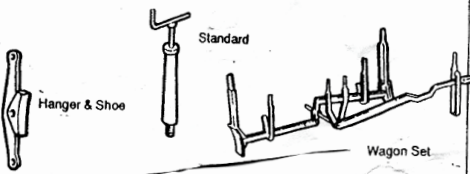

BUFFERS

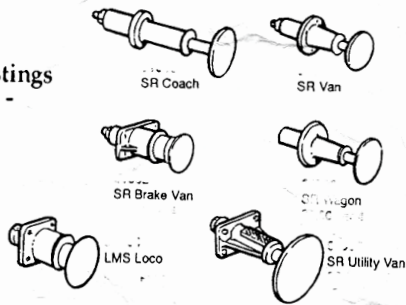

COUPLINGS

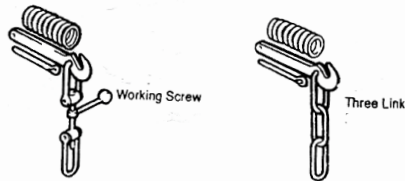

CONNECTING PIPES

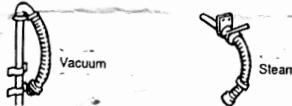

AXLE BOXES

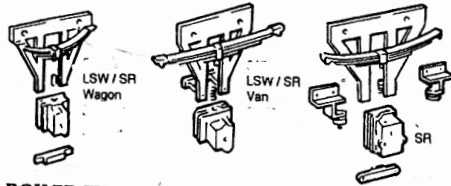

BOILER FITTINGS



MISC.

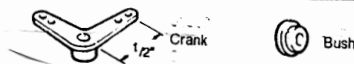

Miscellaneous Lost Wax Wagon Parts

GL-300	3 link Couplings with lost wax hook	£4.00	per pair
GL-304	Oleo Wagon Buffers	£21.85	per 4
GL-315	Instanter couplings	£5.30	per pair
GL-383	NER Wagon Buffer	£21.25	per 4
GL-410	LMS Brake Van Buffers	£21.25	per 4
GL-411	BR/GWR Webbed Buffers	£21.25	per 4
GL-414	Bardic Lamp - drilled to receive LED (not supplied)	£2.35	each
GL-450	G.C.R. Wagon Buffers	£21.25	per 4
GL-451	Met Railway Brake Van Buffers	£21.25	per 4
GL-452	G.N.R. Wagon Buffers	£21.25	per 4
GL-453	LNER Wagon Buffers (4 fins)	£21.25	per 4
GL-454	LMS Wagon Buffers (2 fins)	£21.25	per 4
GL-335	Table Lamps	£2.10	each
GL-336	Pullman square toilet window	£5.30	per pair
GL-343	LNER 'Gresley' Underframe Turnbuckle	£8.00	per 4
GL-344	LNER 'Gresley' Coach Buffers	£21.85	per 4
GL-445	LNER type Long Grab Handles	£3.25	pair
GL-446	LNER Guards Door Handles	£3.25	pair
GL-447	BR Thompson P.B.V. Buffers	£21.85	per 4
GL-468	BR MK 1 coach door commode handles	£2.65	pair
GE-209	Cranked Lamp Irons	£2.35	Per 8
GE-210	Lamp Irons	£3.40	Per 30
GE-211	Hooks (Assorted)	£2.65	Per 16
GE-212	Presflo Valve Wheels	£1.50	Per pair

Scenic Items

Milk churns	set of 4	£2.00
Suitcases	pr	£1.00
Gas lamp standards	ea	£0.75
Gas lamps standards with lamptop & bottom	ea	£1.00
Etch brass platform canopy valance	9" length	£4.50

SECTION I - GAS & ENOTS

Gas Fittings

The introduction of the ARMIG loco seems likely to bring about a resurgence in interest in gas firing, and I am now able to offer standard 1ba threaded AMAL gas jets in a range of sizes. These nominally range from flow rates of 6-1000 cc/minute of petrol. **However, these jets are large by comparison with the size 20 quoted for Roundhouse jets and are not directly comparable.**

The jets are available on increments of 2 in sizes 6 to 22, then in increments of 5 between sizes 25 to 100, and increments of 10 between sizes 100 to 500. All are threaded 1ba to fit a standard holder.

All jets: £ 6.00 each

The poker-type burners for the ARMIG are made to be a push fit in the 3/4" burner flue and come with a size 20 burner jet as standard, but other jets can be supplied on request.

£32.00 each.

ARMIG –type 1-3/4" diameter x 2" gas tanks are available, these are tested to 300 psi and are for butane fuel only. They are supplied with an outlet regulator and Ronson filling valve.

£40.00 each

Miscellaneous gas (£each):

Ceramic honeycomb plates; approx 6" x 4": approx	£12.50
Ronson filler valves:	£5.50
Ronson filler valve with tapped bush (4.5 x 0.5mm)	£7.50
Tap (4.5 x 0.5mm hss) for Ronson filler valve	£17.00
Right angled gas jet holder	£3.75
1ba tap(taper or plug) (carbon steel) for gas jets	£3.90
Gas can filler adaptor:	£15.00

Enots style push fit pressure fittings.

These enable boilers to be filled using a normal hand garden spray. These are reputed to pump up to 600psi and can also be used to form the basis of a boiler testing assembly, although a properly calibrated and certificated pressure gauge will be needed. The fittings are threaded M5 x 0.8.

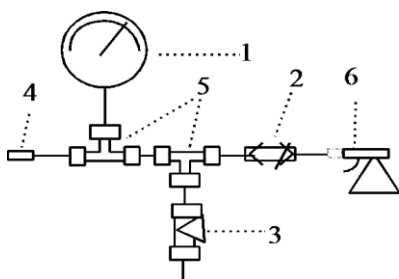

4mm tube fittings £each)

1. Gauges: glycerine filled: 63mm od. FSD choice 30 - 500psi +	£16.50
2. One way non return valves:	£12.50
3. Globe ball valves:	£11.95
4. Straight 4mm tube fittings.	£ 4.60
5. Elbow 4mm tube fittings	£ 6.00
7. 4mm tube Tees.	£ 7.75
9. In line connectors.	£ 5.30
10. Nylon or PTFE pipe	£ 1.00 per ft
11. Trigger spray with ENOT, adaptor and tubing	£10.00

I also stock M5 x 0.5mm c/s taps and dies for making boiler blanking plugs for Aster locos of recent design.

SECTION K - FLUXES & SOLDER

SILVER SOLDER & FLUX

The sale of cadmium-containing alloys such as "Easy Flo No. 2 was banned in the EC740-800, with effect from 9th December 2011.

The best replacement material for general modelling engineering purposes would seem to be Silverflow 55, which has a similar melting point range (610-630°C) to Easyflo No.2. I've tried it for myself and it does flow freely and forms nice fillets. The catch is that it has a higher silver content (55%) and is therefore more expensive. There's no change in the flux needed, Easyflo powder or paste are both fine. For step brazing use Silverflo 24 (740-800°C) as the first step.

Please note: prices as for guidance only as the price of silver fluctuates on a daily basis and the price I have to charged is governed by the day on which I get my supplies!

Silver Solder

Silverflow 55	610-630°C	1.5mm dia x 500mm	£7.70/stick
		1.0mm dia x 500mm	£5.00/stick
		0.5mm wire x 1000mm	£4.50/pack
		0.5mm wire x 2000mm	£8.50/pack
Silverflo 24	740-800°C	1.5mm dia x 600mm	£7.50/stick
Silver solder paste 705-723 °C		10g syringe	£22.50ea

Silver Solder Flux

Flux, Easy Flo powder	100g	£ 9.50
Working range 550-800°C	50g	£ 5.50
	20g	£ 3.50
Flux Easy Flo paste:	50g	£ 5.00
	100g	£ 7.50

Soft Solder

60/40 resin-cored solder mp 183C	100g coil	£9.00
Soft Solder paste mp 183C	50g pot	£6.50
Low melt (70C) solder for whitmetal	Pk	£7.00
Comsol - high temp soft solder (1.5% silver content, mp 296°C)		
	3mm stick, 12"	£6.50
Comsol solder paste	20g pot	£6.50

Section L : Waterslide Transfers

Miscellaneous

WS26	Pullman letters : (Gold shaded red & black)	£3.50
------	---	-------

Pre grouping railway companies

HRY01/1	Highland Railway locomotive sheet1	£24.50
---------	------------------------------------	--------

Lining

LINBRX/1	BR Experimental Blue lining & corners : (White/black/white) (Also suitable	£4.60
LINGWR/	GWR/BR lining & corners : (Orange/black/orange)	£4.60
LINLNE/1	LNWR/BR Lining & corners : (White/black/white)	£4.60
LINLNW/	LNWR/BR Lining & corners : (Grey/red.)	£7.20
LINMET/1	Yellow/black/yellow lining for Metropolitan, Barry etc. : (Yellow/black/yellow)	£4.60
LINMXD/1	Boiler bands for LNW & BR mixed traffic livery : (Red)	£7.20

1923-48 Big 4 livery wagons

9609	GWR Large initials : (White)	£4.60
9611	GWR Large initials. For use with white vehicles : (Red)	£4.60
9792	GWR Micas : (Red)	£5.70
JTT/T1	Big 4 Sheet of white letters, sufficient for up to 4 wagons, all four companies on one sheet	£2.40
JTT/T2	SR Red wagon lettering	£2.40

1948-65 livery Wagons

9701	BR std. 12t. ventilated van. Enough markings for six vans. :	£5.70
9702	BR std. 16t. Mineral Wagon m., Q Diagram 1/108.	£5.70
9709	BR 20ton Brake VN 1948-65 (will letter 6 vans including areas & allocations)	£5.70
9753	BR. 20 ton Brake Van. 1965-1990 (will letter 6 vans, including areas & allocations).	£5.70
9716	BR 12T. fish Van 'BLUE SPOT'. Complete with blue spots and Route Markings.	NYA

1965-90 livery Wagons

9753	BR. 20 ton Brake Van. (will letter 6 vans, including areas & allocations)	£5.70
------	---	-------

British Railways

48Lion/15	BR Lion over wheel (LH & RH) : (Red, Yellow, black & white)	£2.40
48Lion/25	BR Lion over wheel (LH & RH) : (Red, Yellow, black & white)	£3.50
BRY01/01	BR Cabside numbers 0-9 : (Cream outlined in black)	£2.40

BRY01a/1	BR Cabside numbers 0-9 (White, Scottish Region) : (White outlined in black)	£2.40
57Lion/15	BR Lion Holding Wheel : (Late BR) Tank engine size	£3.50
57Lion/23	BR Lion Holding Wheel : (Late BR) Tender engine size	£5.70
BRY15/01	BR diesel numbers (1957-65) (square serif) 8 sets 0-9 & 'D's : (White)	£3.50
BRY02/1	Electrification flashes (Overhead live wire warning sign)	£2.40

British Railways (Diesel Models)

BRY03/1	BR Arrows : (White)	£4.80
7G402	Late style Lion holding wheel 1956-68 (smaller sizes)	£8.50

Great Western Railway (GWR)

GWR04/1	Great Western 'Twin city' crest : (Finely detailed in 7 colours)	£4.60
GWR06/1	GWR buffer numbers : (Yellow shadowed black)	£3.50
GWR07/1	Great Western' lettering. : (Gold shaded red & black)	£3.50
GWR09/1	GWR cabside route restriction discs & power codes :	£2.70

London & North Eastern Railway (LNER)

LNE02/1	LNER lettering : (Gold shaded red & black, with white highlights)	£4.60
LNE03/1	LNER Cabside numbers : (Gold shaded red & black, with white highlights)	£5.70
LNE08/1	LNER Lettering (Yellow shaded red & black with white highlights)	£5.70
LNE09/1	LNER Cabside numbers : (Gold shaded red & black, with white highlights)	£5.70

London, Midland & Scottish Railway (LMS)

LMS04/1	LMS serif 14" letters : (Gold shaded black)	£3.50
LMS06/1	LMS serif 12" numbers : (Gold shaded black)	£3.50
LMS13/1	LMS letters (later yellow style) : (Yellow shaded red)	NYA
LMS14/1	LMS numbers (later yellow style) : (Yellow shaded red)	£3.50

Southern Railway (SR)

SRY02/1	Southern Maunsell lettering: (Yellow)	£5.80
SRY02/2	Southern Maunsell numerals	£5.90

Caledonian Railway (CR)

CR02/1	"C R lettering"
--------	-----------------

Narrow Gauge

NG01/3	Welsh Highland & NWNCR Wagons
NG02/3	Festiniog slate wagons
04/3	/SM32

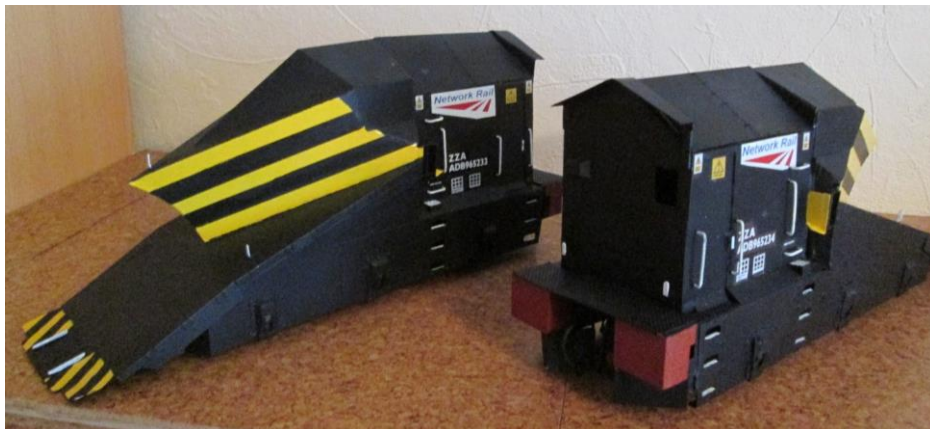

Above: A pair of BR 6-wheel snowploughs built from JTT kits by Pat Honey